



### Resistor

100R2J-2-GP

Before "R" is the Resistance  
ex: 100R=100 ohm; 49K9R=49.9K ohm  
80D6R=80.6 ohm

2=0402  
3=0603  
5=0805

J=5%  
F=1%  
D=0.5%

Serial #;  
Some parts no this #

-GP=RoHS Part  
-PAD=no component just  
layout pad connected

### Capacitor

SC4D7U10V5ZY-3GP

4D7U is the Capacitance  
ex:4D7U =4.7UF; SC100P=100PF

10V is the Rated Voltage

0=1210  
2=0402  
3=0603  
5=0805  
6=1206

-3GP is serial #  
and RoHS Part

Tolerance  
ZY=Y5V  
MX=X5R  
KX=X5R  
JN=NPO

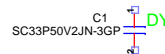

DY means de-populate

DUMMY

<b>緯創資通</b>		<b>Wistron Corporation</b>	
		<small>21F, 88, Sec.1, Hsin Tai Wu Rd., Hsichih, Taipei Hsien 221, Taiwan, R.O.C.</small>	
<b>Reference</b>			
Size A3	Document Number <b>LS205 MB</b>		Rev <b>SB</b>
Date: Tuesday, December 21, 2010		Sheet 2	of 48

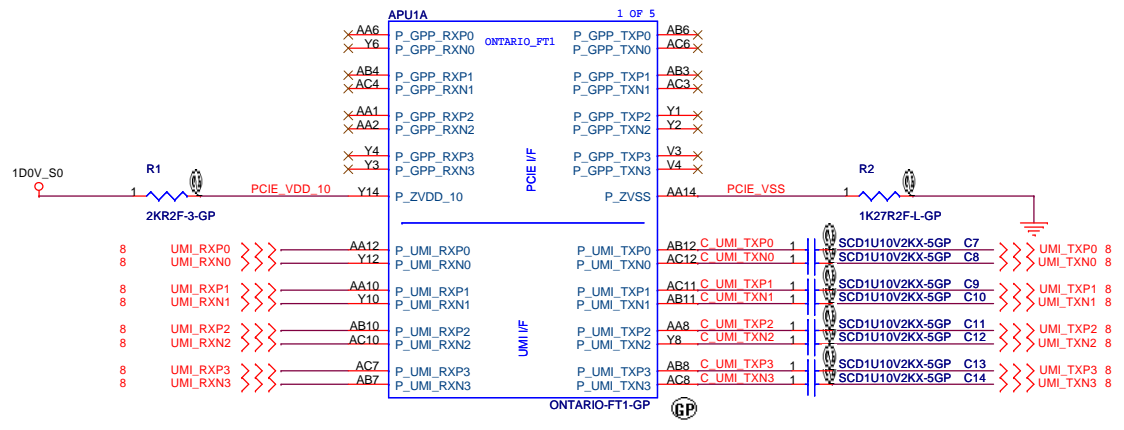

DUMMY

<b>Wistron Corporation</b> 21F, 88, Sec. 1, Hsin Tai Wu Rd., Hsichih, Taipei Hsien 221, Taiwan, R.O.C.	
<b>APU 1 of 5(UMI/PCIE)</b>	
Title <b>APU 1 of 5(UMI/PCIE)</b>	Document Number <b>LS205 MB</b>
Size A3	Rev <b>SB</b>
Date: Tuesday, December 21, 2010	
Sheet 3 of 48	

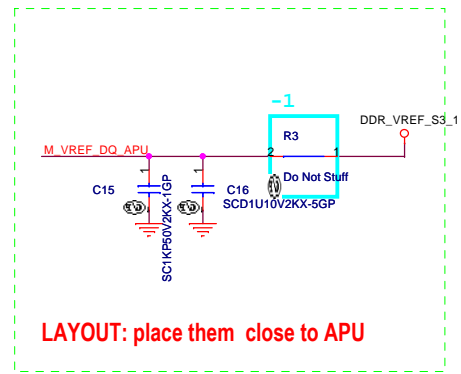
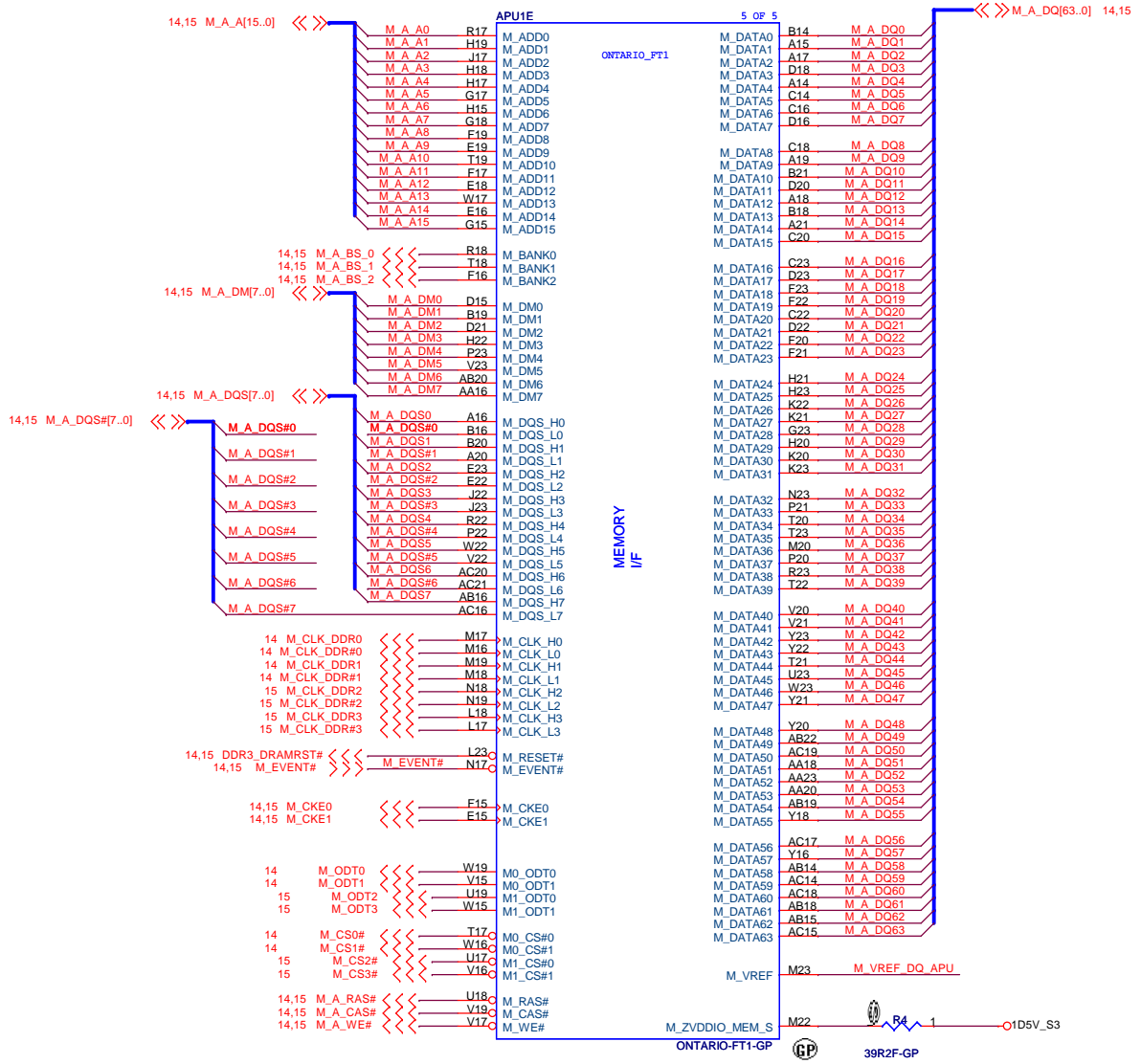

LAYOUT: place them close to APU

DUMMY

**緯創資通 Wistron Corporation**  
 21F, 88, Sec. 1, Hsin Tai Wu Rd., Hsichih, Taipei Hsien 221, Taiwan, R.O.C.

Title: **APU 2 of 5(DDR)**

Size A3 | Document Number: **LS205 MB** | Rev: **SB**

Date: Tuesday, December 21, 2010 | Sheet 4 of 48





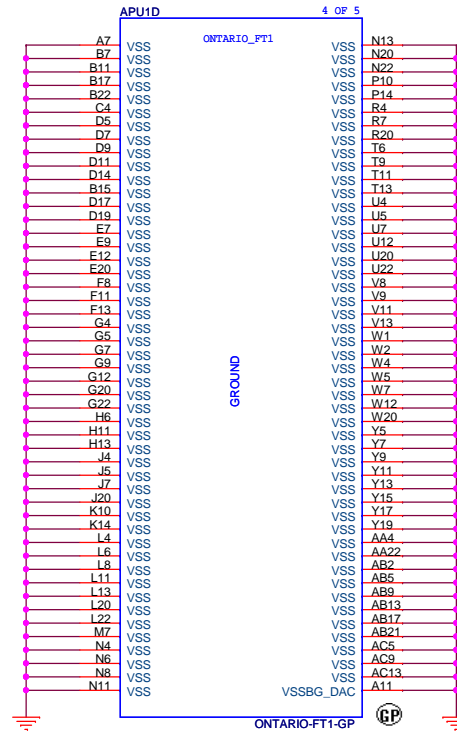

DUMMY

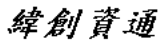
 <b>Wistron Corporation</b> 21F, 88, Sec. 1, Hsin Tai Wu Rd., Hsichih, Taipei Hsien 221, Taiwan, R.O.C.		
<b>APU 5 of 5(VSS)</b>		
Size A3	Document Number <b>LS205 MB</b>	Rev <b>SB</b>
Date: Tuesday, December 21, 2010		
Sheet 7 of 48		





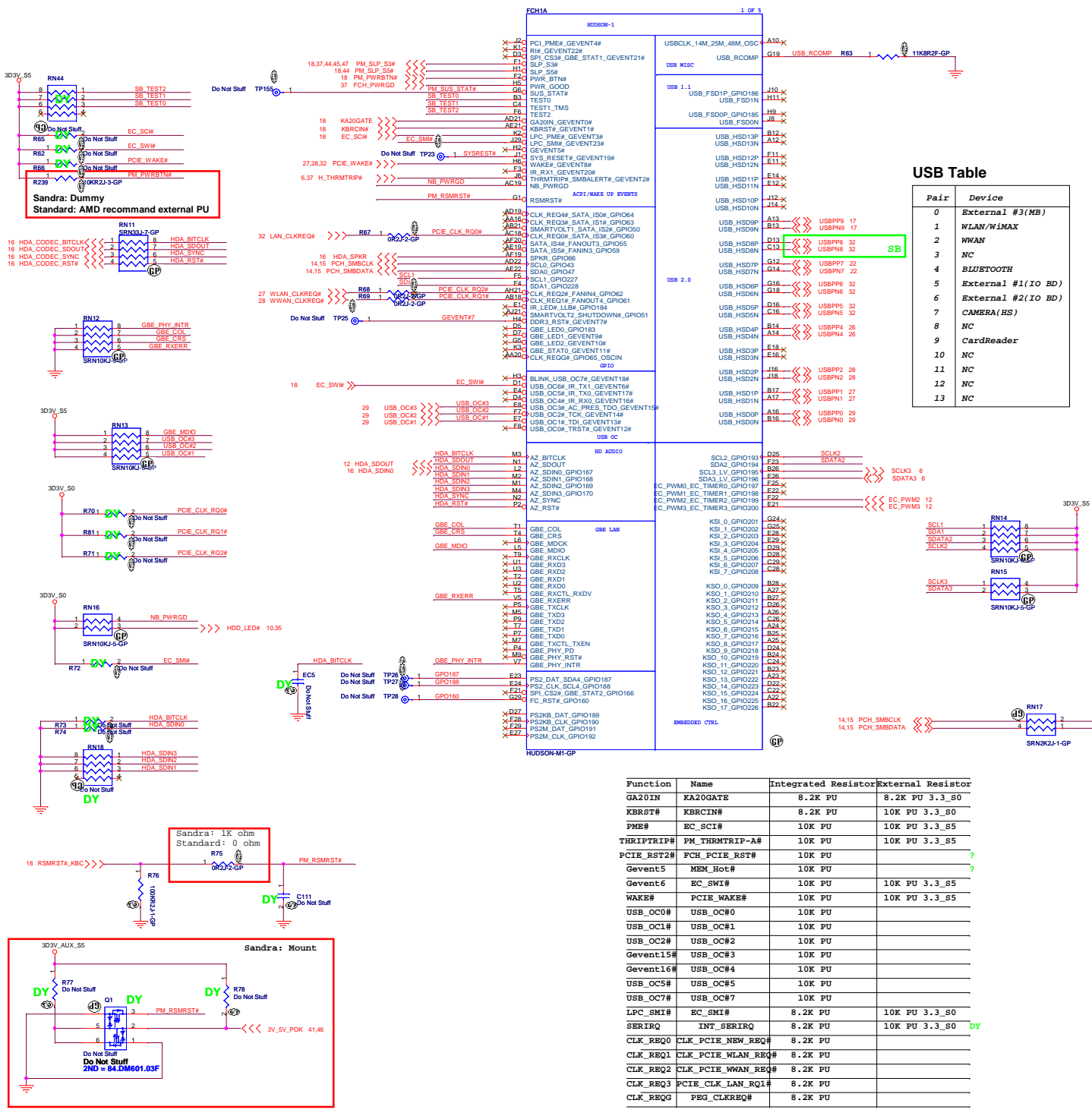

### USB Table

Pair	Device
0	External #3(MB)
1	WLAN/WIMAX
2	WWAN
3	NC
4	BLUETOOTH
5	External #1(IO BD)
6	External #2(IO BD)
7	CAMERA(HS)
8	NC
9	CardReader
10	NC
11	NC
12	NC
13	NC

Function	Name	Integrated Resistor	External Resistor
GA20IN	KA20GATE	8.2K PU	8.2K PU 3.3_80
KBRST#	KBRGIN#	8.2K PU	10K PU 3.3_80
PME#	EC_SCI#	10K PU	10K PU 3.3_85
THRIPTRIP#	PM_THRMTRIP-A#	10K PU	10K PU 3.3_85
PCIE_RST2#	FCH_PCIE_RST#	10K PU	10K PU
Gevent5	MEM_Hot#	10K PU	10K PU
Gevent6	EC_SWI#	10K PU	10K PU 3.3_85
WAKE#	PCIE_WAKE#	10K PU	10K PU 3.3_85
USB_OC0#	USB_OC#0	10K PU	
USB_OC1#	USB_OC#1	10K PU	
USB_OC2#	USB_OC#2	10K PU	
Gevent15#	USB_OC#3	10K PU	
Gevent16#	USB_OC#4	10K PU	
USB_OC5#	USB_OC#5	10K PU	
USB_OC7#	USB_OC#7	10K PU	
LPC_SMI#	EC_SMI#	8.2K PU	10K PU 3.3_80
SERIRQ	INT_SERIRQ	8.2K PU	10K PU 3.3_80
CLK_REQ0	CLK_PCIE_NEW_REQ#	8.2K PU	
CLK_REQ1	CLK_PCIE_WLAN_REQ#	8.2K PU	
CLK_REQ2	CLK_PCIE_WWAN_REQ#	8.2K PU	
CLK_REQ3	PCIE_CLK_LAN_RQ1#	8.2K PU	
CLK_REQ0	PEG_CLKREQ#	8.2K PU	

Sandra: Dummy  
Standard: AMD recommend external PU

Sandra: 1K ohm  
Standard: 0 ohm

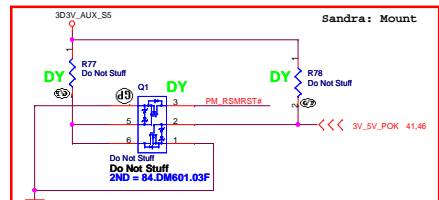

HDD

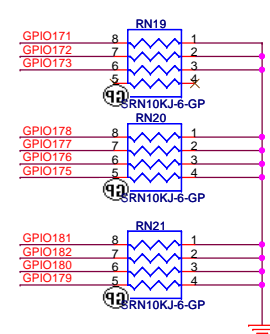
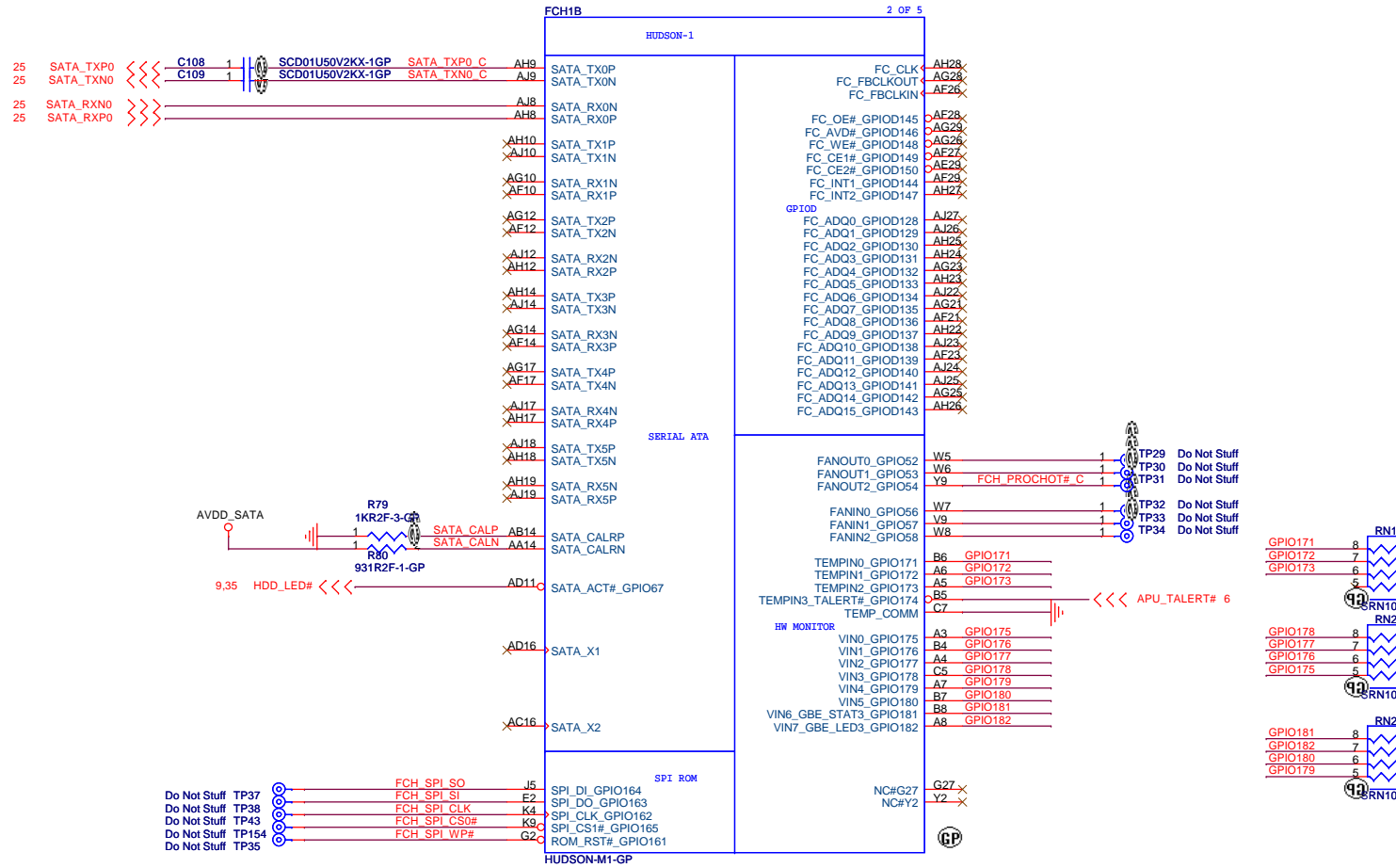

DUMMY

**緯創資通 Wistron Corporation**  
21F, 88, Sec.1, Hsin Tai Wu Rd., Hsichih, Taipei Hsien 221, Taiwan, R.O.C.

Title: **FCH 3 of 6(SPI/SATA)**

Size A3	Document Number <b>LS205 MB</b>	Rev <b>SB</b>
---------	---------------------------------	---------------

Date: Tuesday, December 21, 2010 Sheet 10 of 48

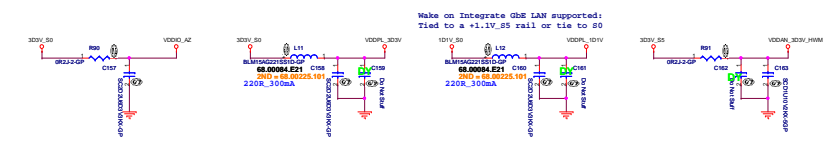
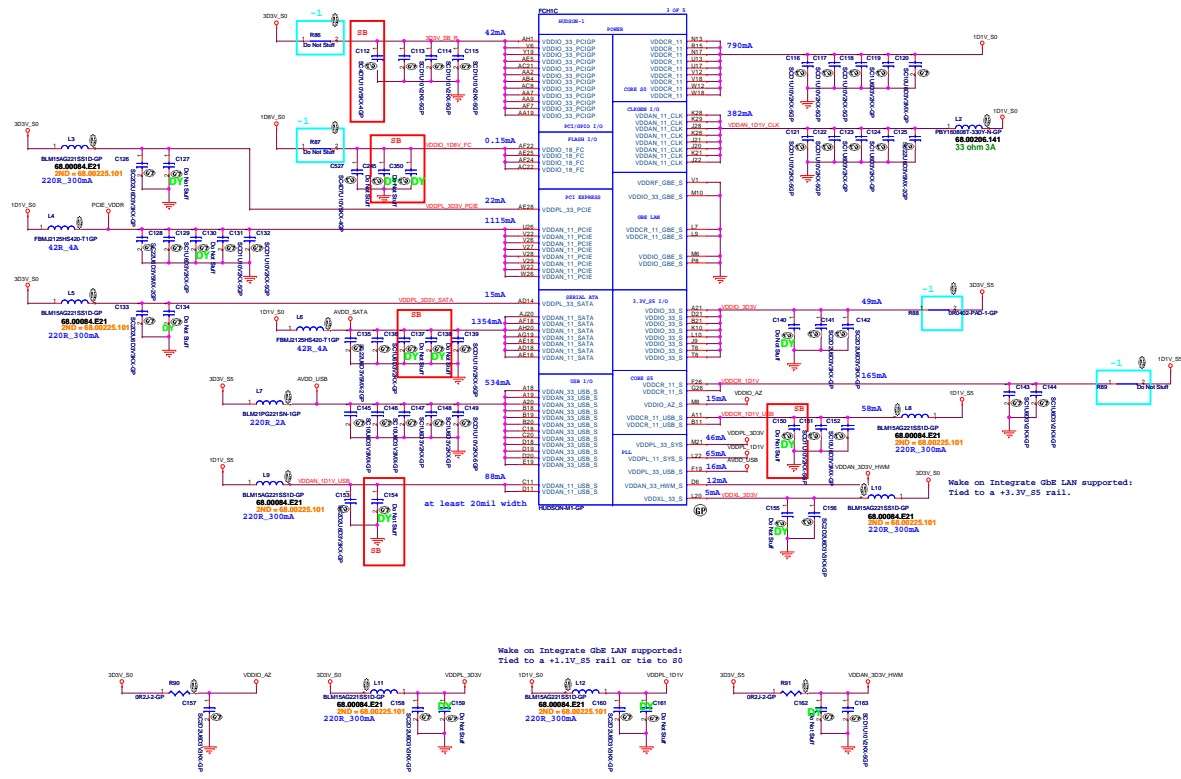

### REQUIRED STRAPS

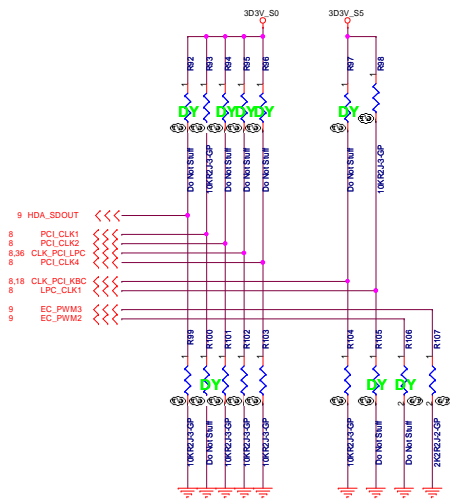

CRB:PU 3.3V\_AUX\_S5  
 checklist:PU 3.3V\_95  
 confirm by AMD, following CRB suggestion

### REQUIRED SYSTEM STRAPS

	AZ_SDOUT (ACZ_SDATAOUT_1)	PCI_CLK1	PCI_CLK2	PCI_CLK3 (CLK_PCL_LPC)	PCI_CLK4	LPC_CLK0 (CLK_PCL_KBC)	LPC_CLK1 (PCLK_FWH)
PULL HIGH	Low Power Mode	Allow PCIE GEN2 DEFAULT	Watchdog Timer Enabled	USE DEBUG STRAPS	non_Fusion CLOCK mode	ENABLE EC	CLKGEN ENABLED (Use Internal) DEFAULT
PULL LOW	Performance Mode DEFAULT	Force PCIE GEN1	Watchdog Timer Disabled DEFAULT	IGNORE DEBUG STRAPS DEFAULT	Fusion CLOCK mode DEFAULT	DISABLE EC DEFAULT	CLKGEN DISABLED (Use External)

USE this pin to determine INT/EXT CLK

TYPE ENABLED	EC_PWM2	EC_PWM3
Reserved	2.2-kohm 5% pull-down	2.2-kohm 5% pull-down
LPC ROM	Not connected.	2.2-kohm 5% pull-down
SPI ROM	2.2-kohm 5% pull-down	Not connected.
Reserved	Not connected.	Not connected.

Note: EC\_PWM2, EC\_PWM3 default have internal 10kohm PU.

### DEBUG STRAPS

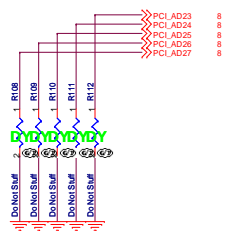

	PCI_AD27	PCI_AD26	PCI_AD25	PCI_AD24	PCI_AD23
PULL HIGH	USE PCI PLL (DEFAULT)	Disable ILA AUTORUN (DEFAULT)	USE FC PLL (DEFAULT)	USE DEFAULT PCIE STRAPS (DEFAULT)	Disable PCI MEM BOOT (DEFAULT)
PULL LOW	BYPASS PCI PLL	Enable ILA AUTORUN	BYPASS FC PLL	USE EEPROM PCIE STRAPS	Enable PCI MEM BOOT

Note: FCH has 15K internal PU FOR PCI\_AD[27:23]

DUMMY

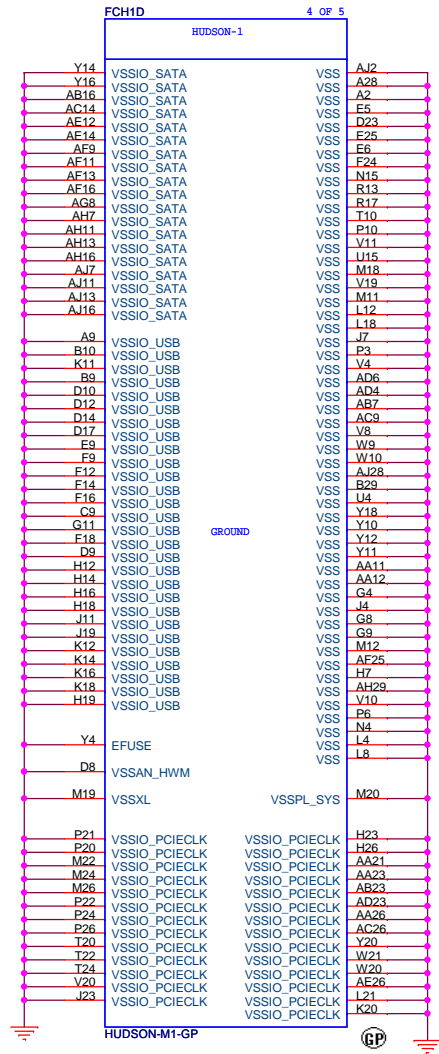

DUMMY

緯創資通 Wistron Corporation  
 21F, 88, Sec. 1, Hsin Tai Wu Rd., Hsichih,  
 Taipei Hsien 221, Taiwan, R.O.C.

Title FCH 6 of 6(VSS)

Size A3 Document Number LS205 MB Rev SB

Date: Tuesday, December 21, 2010 Sheet 13 of 48





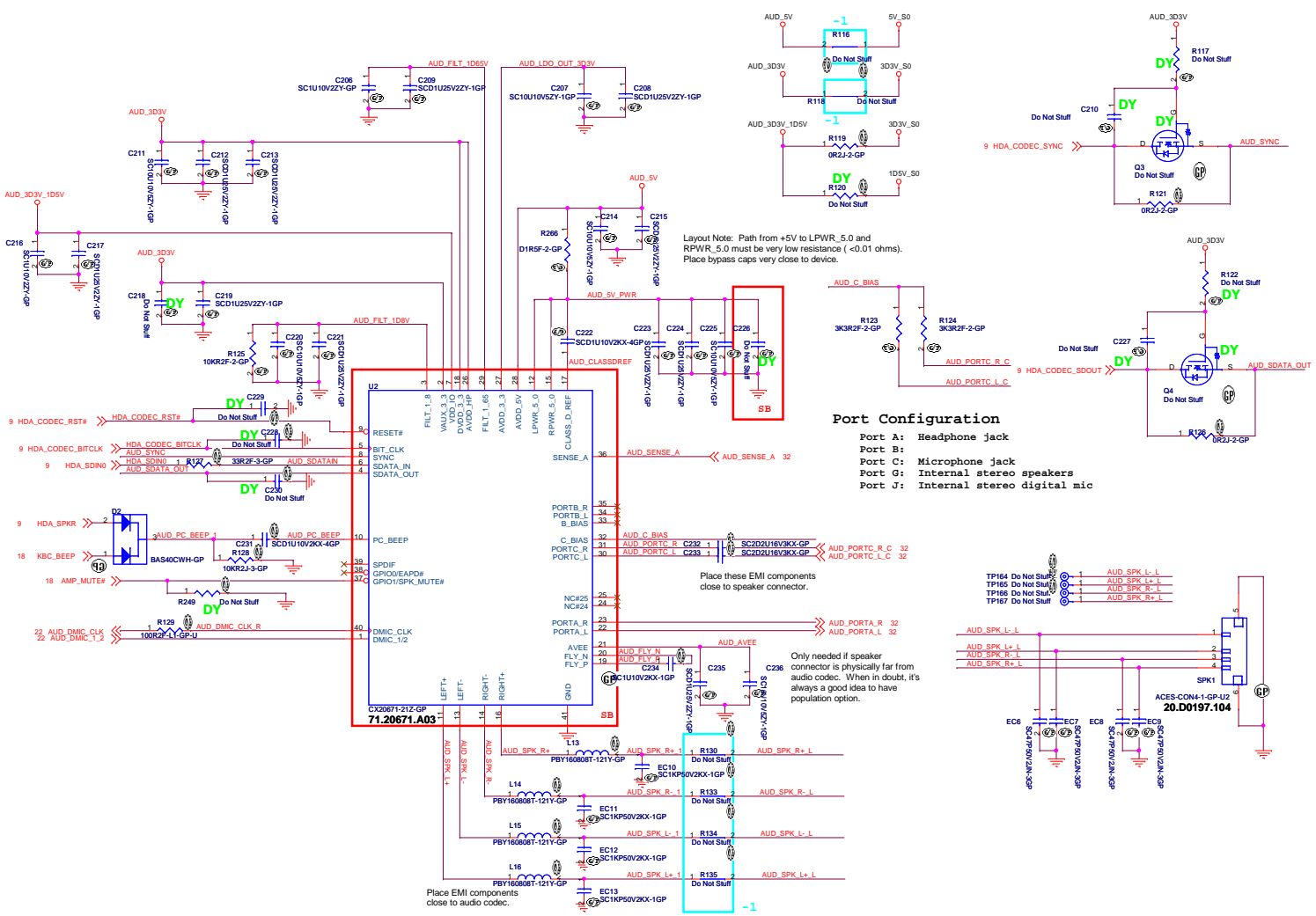

Layout Note: Path from +5V to LPWR\_5.0 and RPWR\_5.0 must be very low resistance (<0.01 ohms). Place bypass caps very close to device.

### Port Configuration

- Port A: Headphone jack
- Port B: Headset microphone
- Port C: Microphone jack
- Port G: Internal stereo speakers
- Port J: Internal stereo digital mic

Place these EMI components close to speaker connector.

Only needed if speaker connector is physically far from audio codec. When in doubt, it's always a good idea to have population option.

Place EMI components close to audio codec.

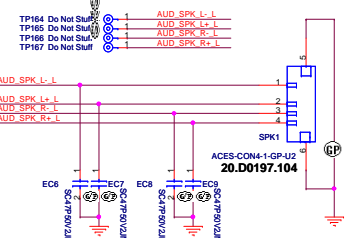
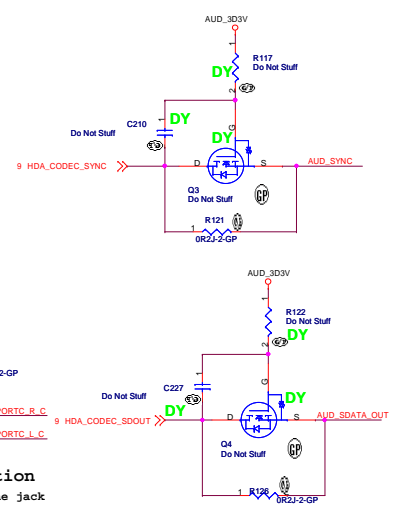



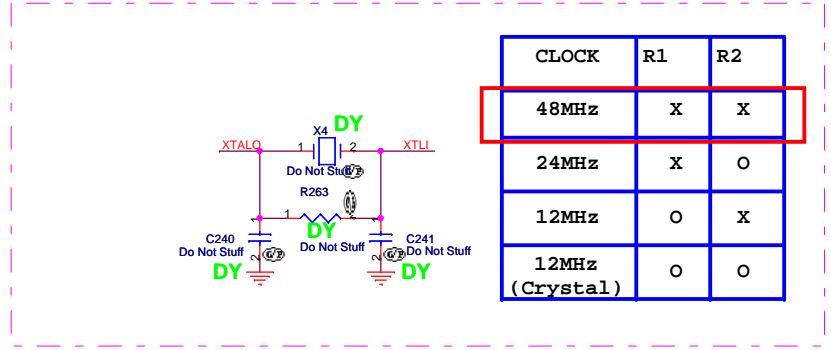
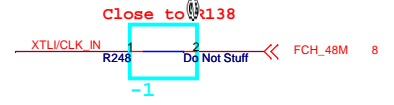
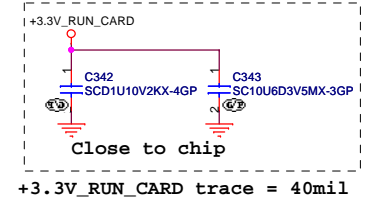
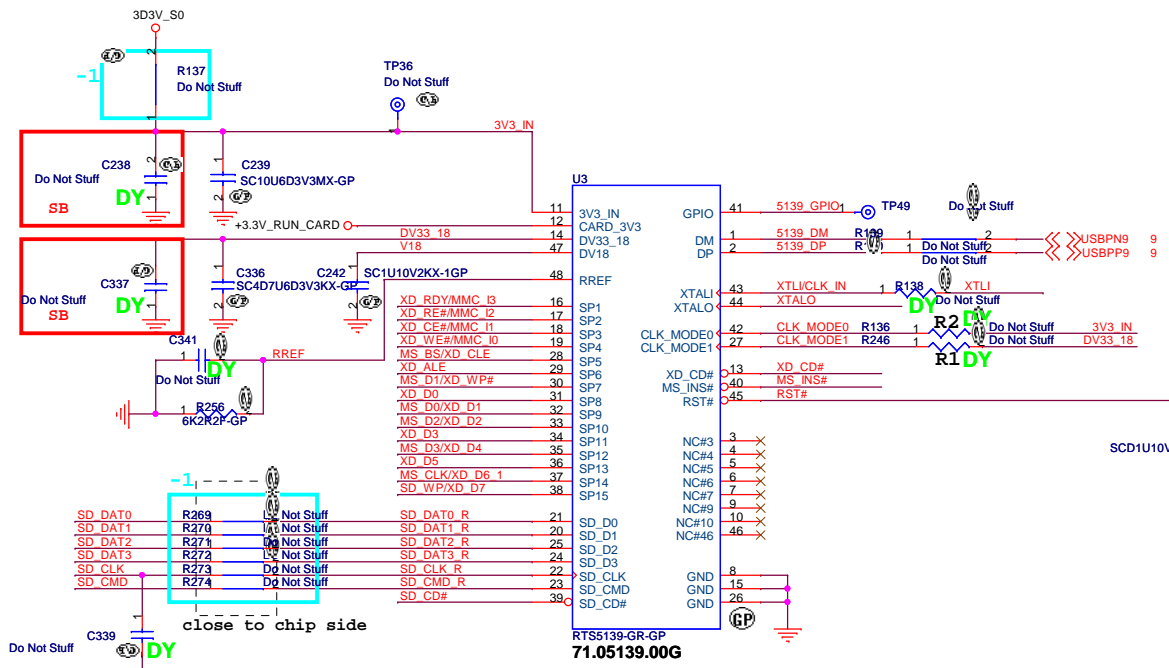

# 6 IN 1 CONN

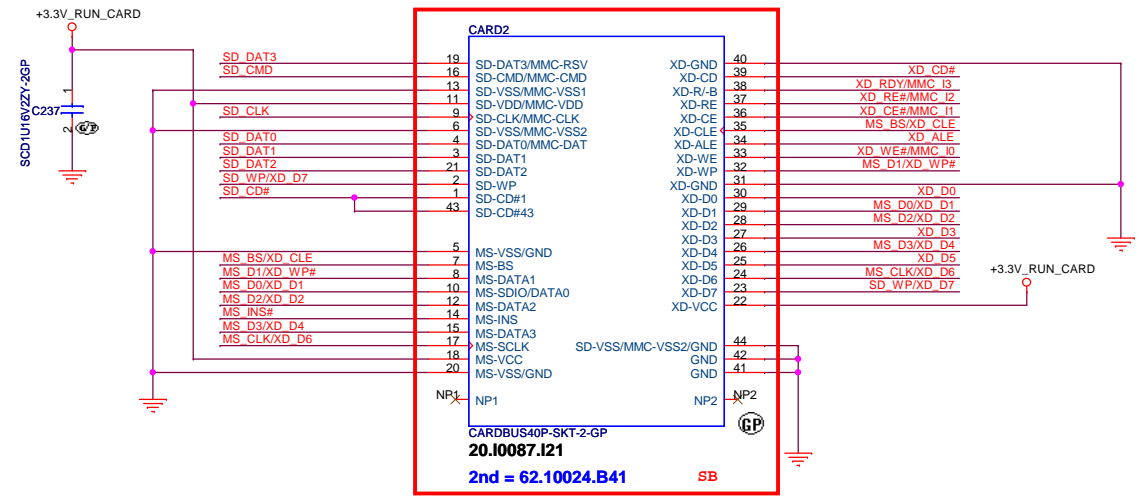

DUMMY

**緯創資通** Wistron Corporation  
21F, 88, Sec.1, Hsin Tai Wu Rd., Hsichih, Taipei Hsien 221, Taiwan, R.O.C.

Title: **CardReader RTS5139**

Size: Document Number **LS205 MB** Rev: **SB**

Date: Tuesday, December 21, 2010 Sheet 17 of 48



# G-Sensor

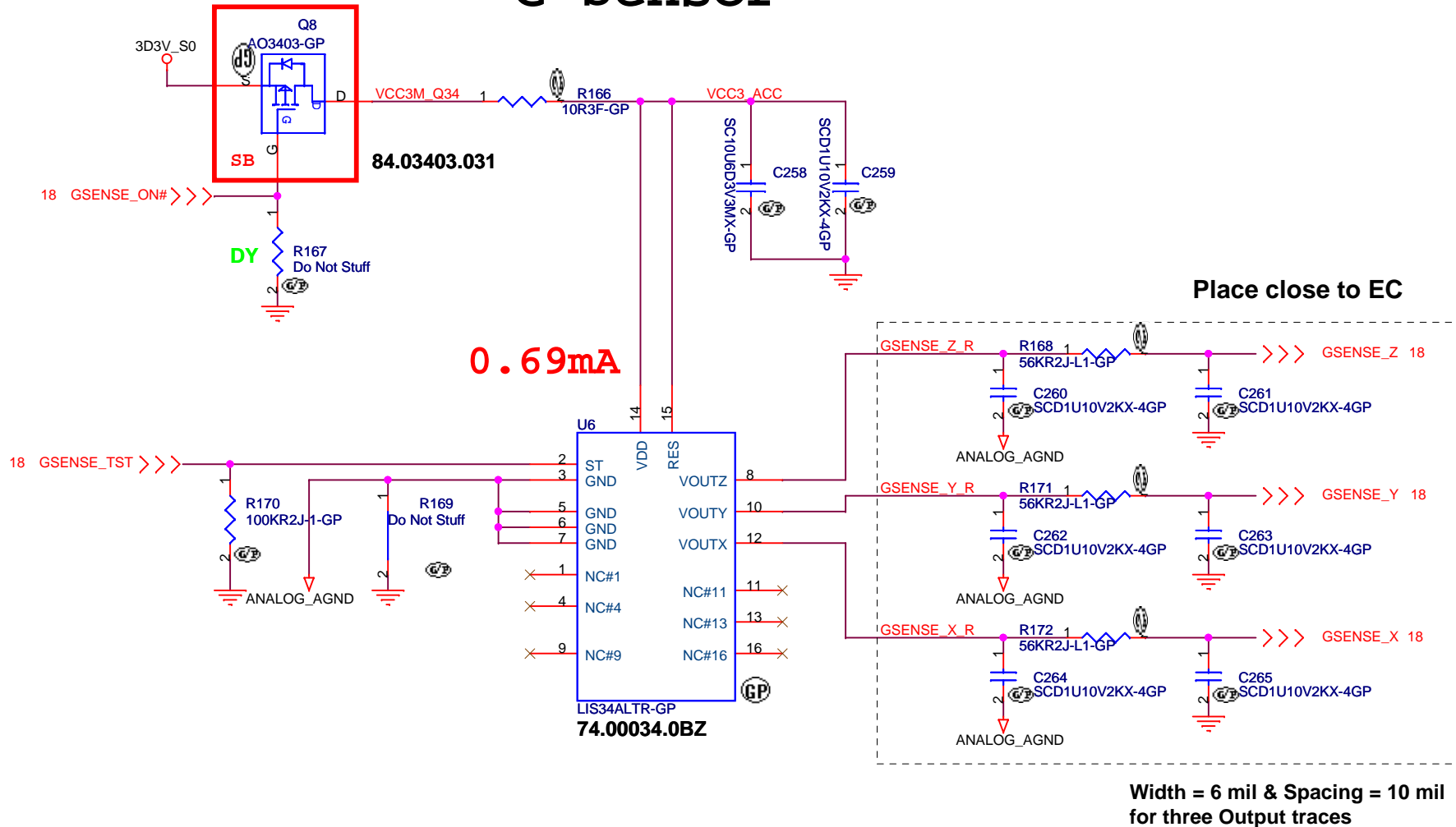

0.69mA

Place close to EC

Width = 6 mil & Spacing = 10 mil  
for three Output traces

	ADXL322	
	LIS244AL	No Accel
	LIS34AL	
R530	NO_ASM	ASM
R509	ASM	ASM
All other	ASM	NO_ASM

STMicro LIS34AL: 74.00034.0BZ  
ADXL335 : 74.00335.0BZ

**Layout Comment :**

(1) Place C304, C305, Q19, R185, R188, C307, C309, C311, R187 close to U10.

(2) Avoid routing under DCDC switching area.

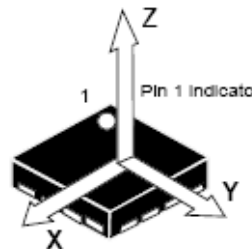

DUMMY

		<b>Wistron Corporation</b> 21F, 88, Sec.1, Hsin Tai Wu Rd., Hsichih, Taipei Hsien 221, Taiwan, R.O.C.	
Title			
<b>G-Sensor</b>			
Size	Document Number		Rev
	<b>LS205 MB</b>		<b>SB</b>
Date:	Tuesday, December 21, 2010		Sheet 19 of 48

# Hall Sensor

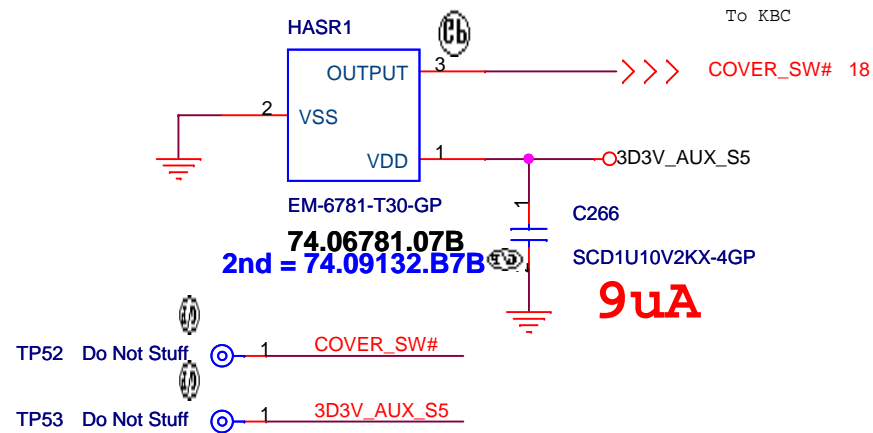

DUMMY

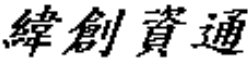
 <b>Wistron Corporation</b> 21F, 88, Sec.1, Hsin Tai Wu Rd., Hsichih, Taipei Hsien 221, Taiwan, R.O.C.	
Title <b>HALL Sensor</b>	
Size	Document Number <b>LS205 MB</b>
Rev <b>SB</b>	
Date: Tuesday, December 21, 2010	
Sheet	20 of 48

Close to PCH on top side.

SA 0905 change to 390p

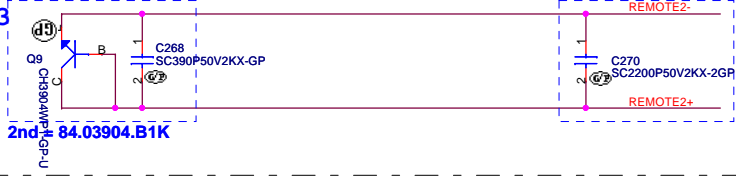

close to smsc2103 chip

T8

2nd = 84.03904.B1K

close to smsc2103 chip

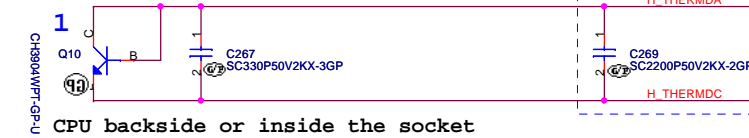

CPU backside or inside the socket

CPU TEMP:

H\_THERMDA and H\_THERMDC routing 10mil trace width and spacing. Locate Capacity near Thermal diode.

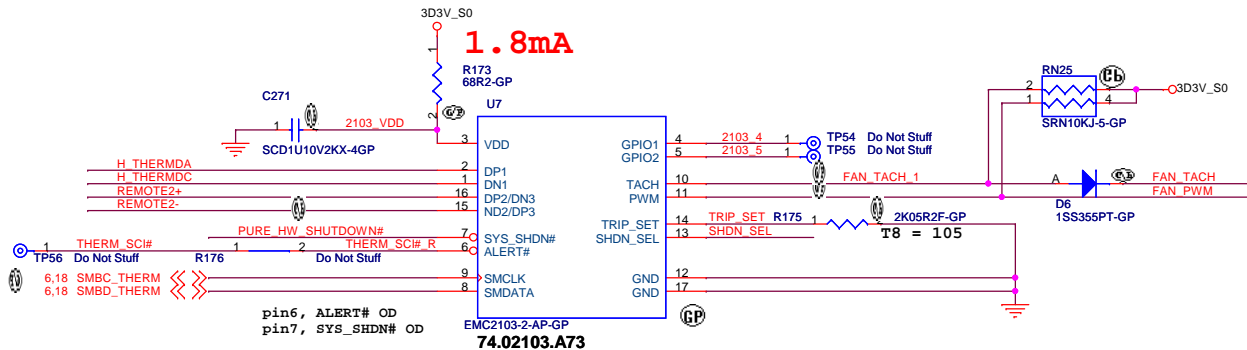

1.8mA

Close to connector 5V\_S0 20 mil

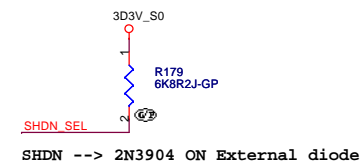
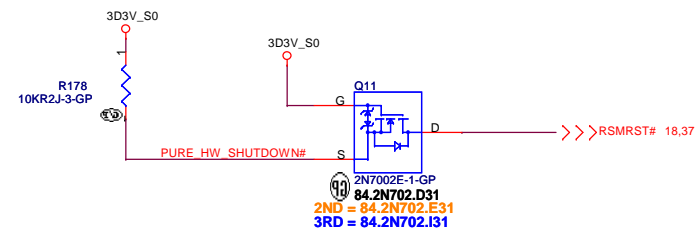
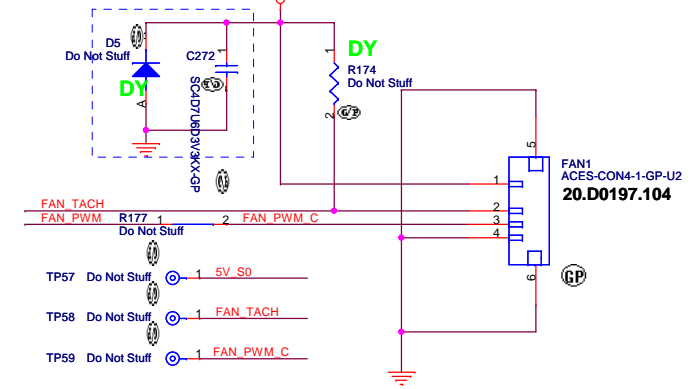

SHDN --> 2N3904 ON External diode

# LCD CONNECTOR

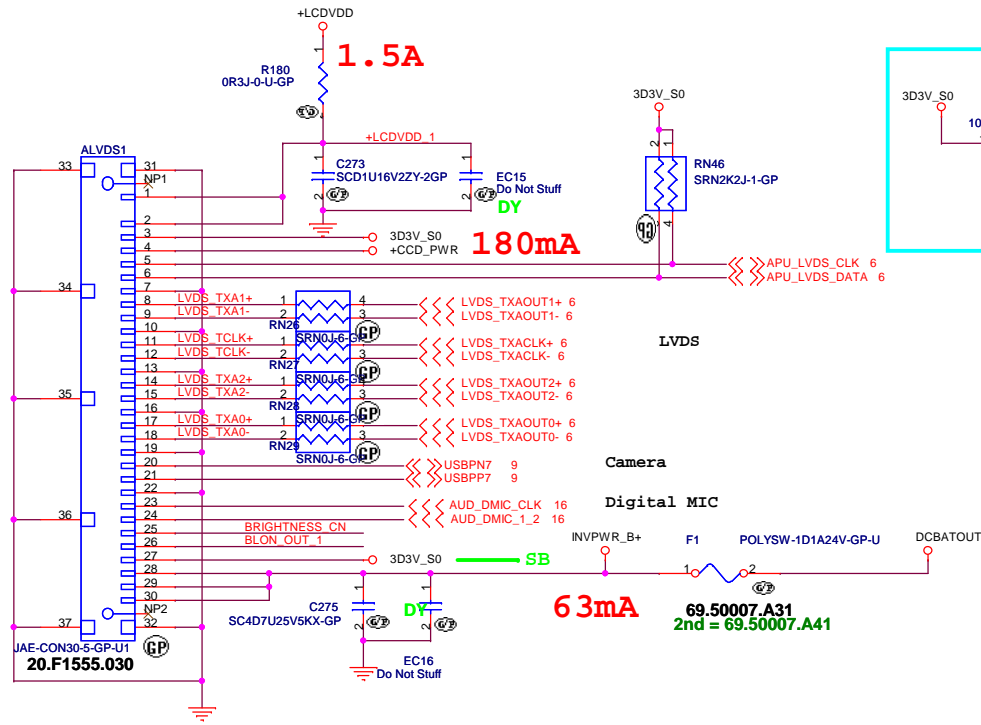

# BL

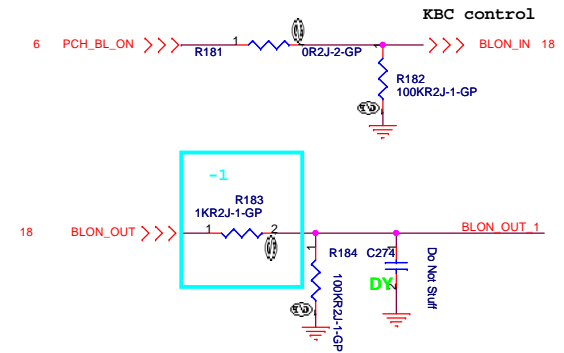

# BRIGHTNESS

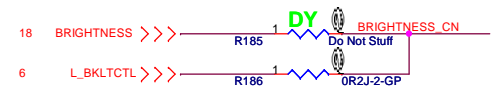

# LCD Power & Discharge

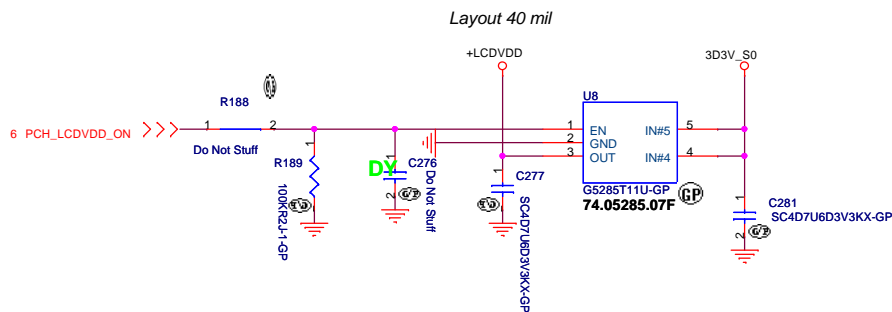

# CAMERA POWER

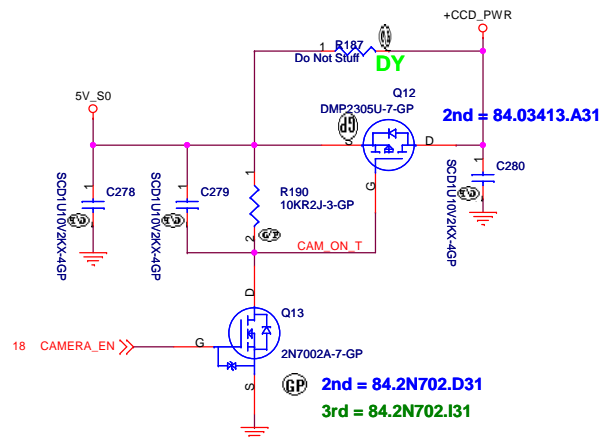

DUMMY

緯創資通 Wistron Corporation  
 21F, 88, Sec.1, Hsin Tai Wu Rd., Hsichih, Taipei Hsien 221, Taiwan, R.O.C.

Title <b>LCD CONN</b>		
Size	Document Number <b>LS205 MB</b>	Rev <b>SB</b>
Date: Tuesday, December 21, 2010	Sheet 22	of 48

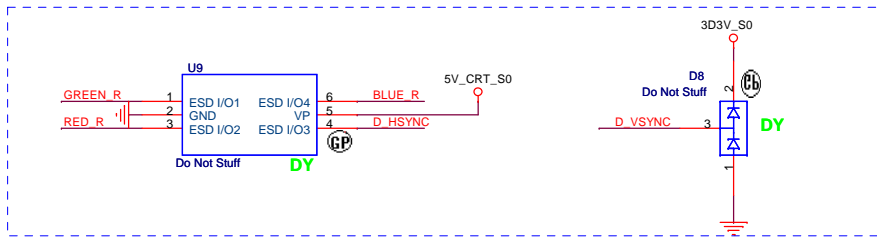
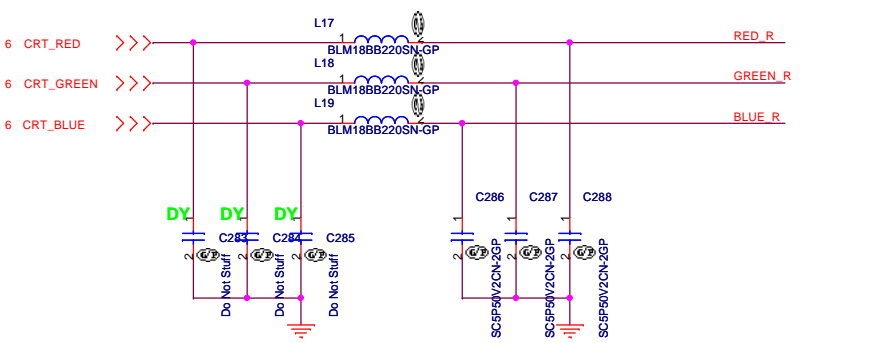

Place near the CRT connector

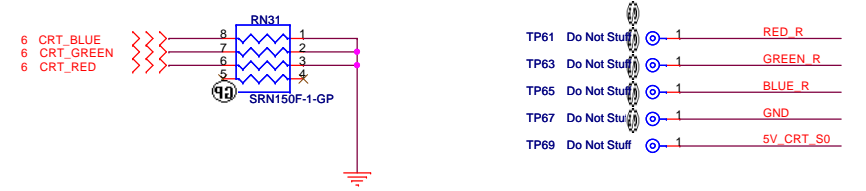

## HSYNC & VSYNC

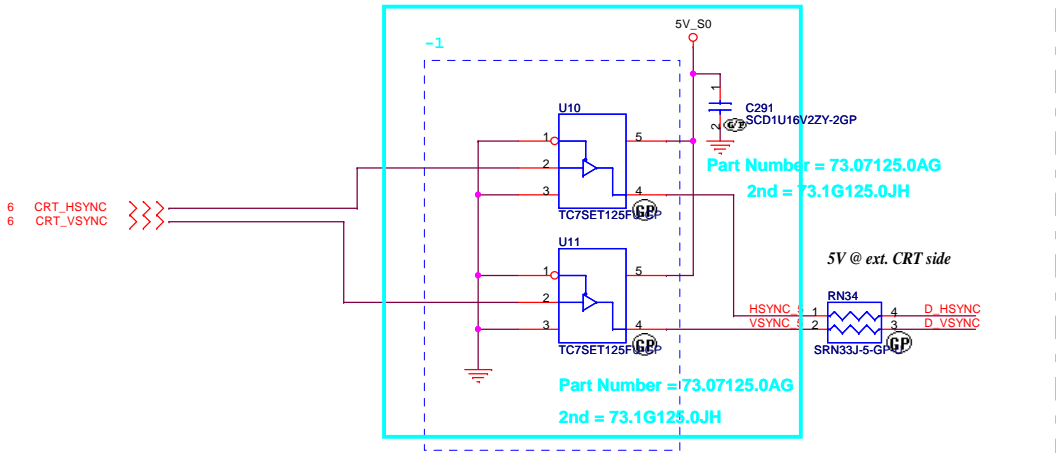

PLACE CLOSE TO PCH

## CRT connector

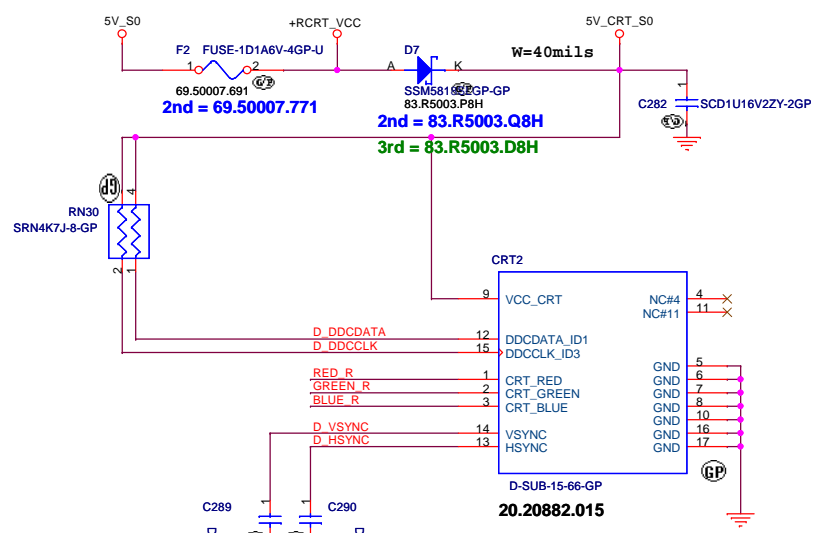

PLACE CLOSE TO PCH

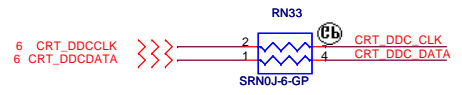
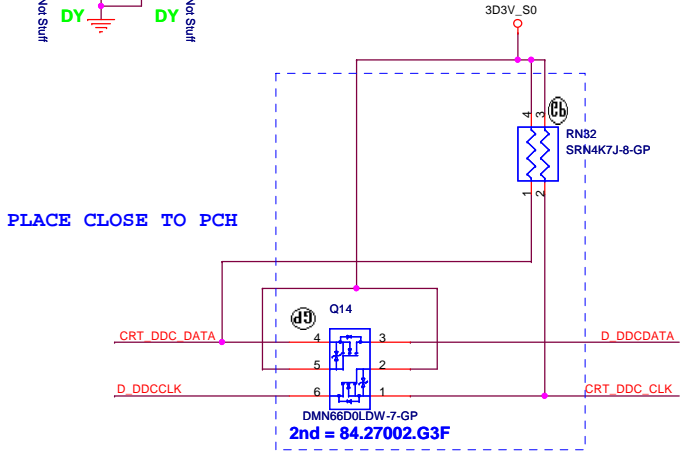

DUMMY

<b>Wistron Corporation</b> 21F, 88, Sec. 1, Hsin Tai Wu Rd., Hsichih, Taipei Hsien 221, Taiwan, R.O.C.	
<b>CRT CONN</b>	
Title <b>LS205 MB</b>	Rev <b>SB</b>
Size Document Number	Date: Tuesday, December 21, 2010
Date: Tuesday, December 21, 2010	Sheet 23 of 48

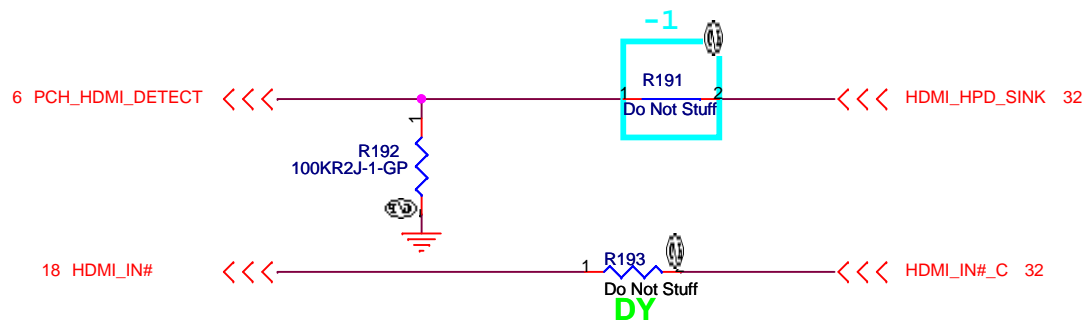

DUMMY

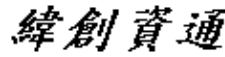
 <b>Wistron Corporation</b> 21F, 88, Sec.1, Hsin Tai Wu Rd., Hsichih, Taipei Hsien 221, Taiwan, R.O.C.		
<b>Title</b> <b>HDMI CONN</b>		
Size	Document Number	Rev
	<b>LS205 MB</b>	<b>SB</b>
Date:	Tuesday, December 21, 2010	Sheet 24 of 48



# SATA HDD Connector

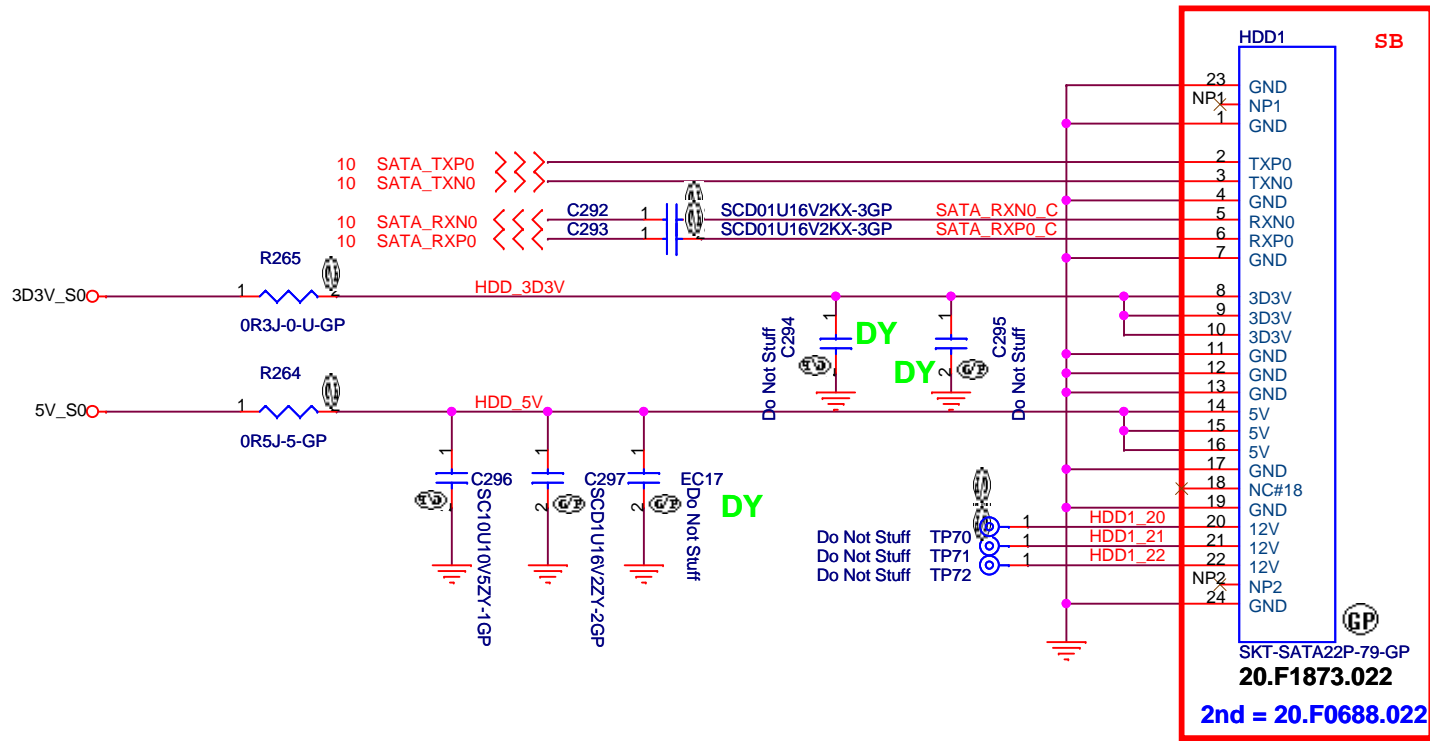

DUMMY

**Wistron Corporation**  
 21F, 88, Sec.1, Hsin Tai Wu Rd., Hsichih,  
 Taipei Hsien 221, Taiwan, R.O.C.

Title		
<b>HDD CONN</b>		
Size	Document Number	Rev
	<b>LS205 MB</b>	<b>SB</b>
Date:	Tuesday, December 21, 2010	Sheet 25 of 48

# Bluetooth Power

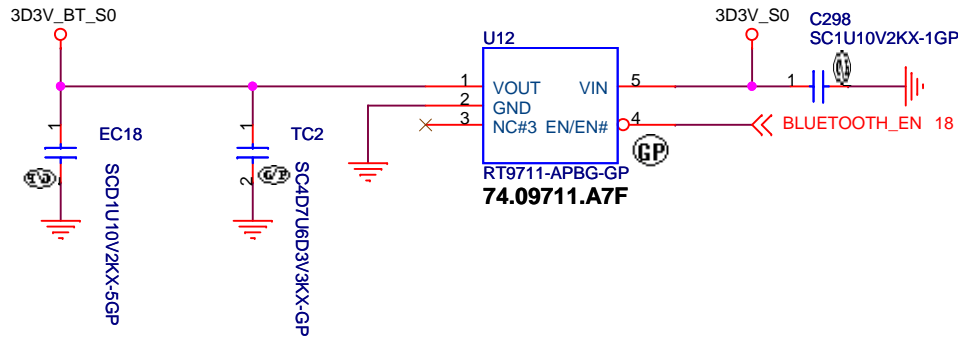

# BT CONN.

**200mA**

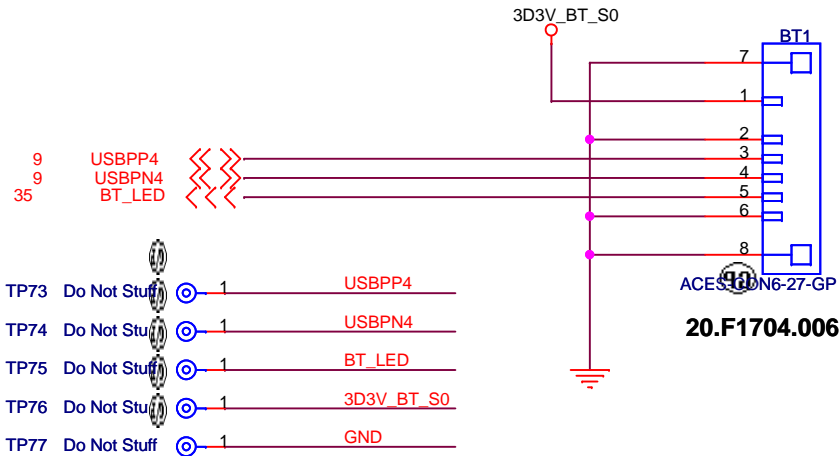

DUMMY

		<b>Wistron Corporation</b> 21F, 88, Sec.1, Hsin Tai Wu Rd., Hsichih, Taipei Hsien 221, Taiwan, R.O.C.	
<b>Bluetooth CONN</b>			
Size	Document Number		Rev
	<b>LS205 MB</b>		<b>SB</b>
Date: Tuesday, December 21, 2010		Sheet 26 of 48	

# Mini Card Connector(WLAN)

## Half minicard

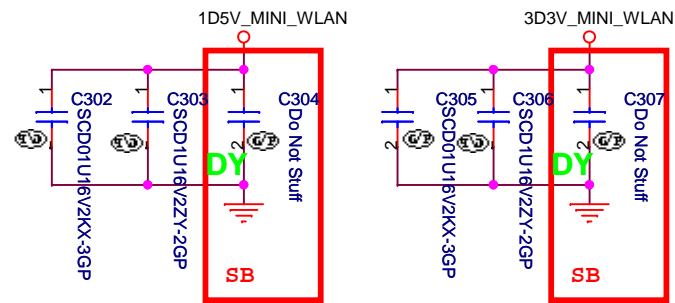
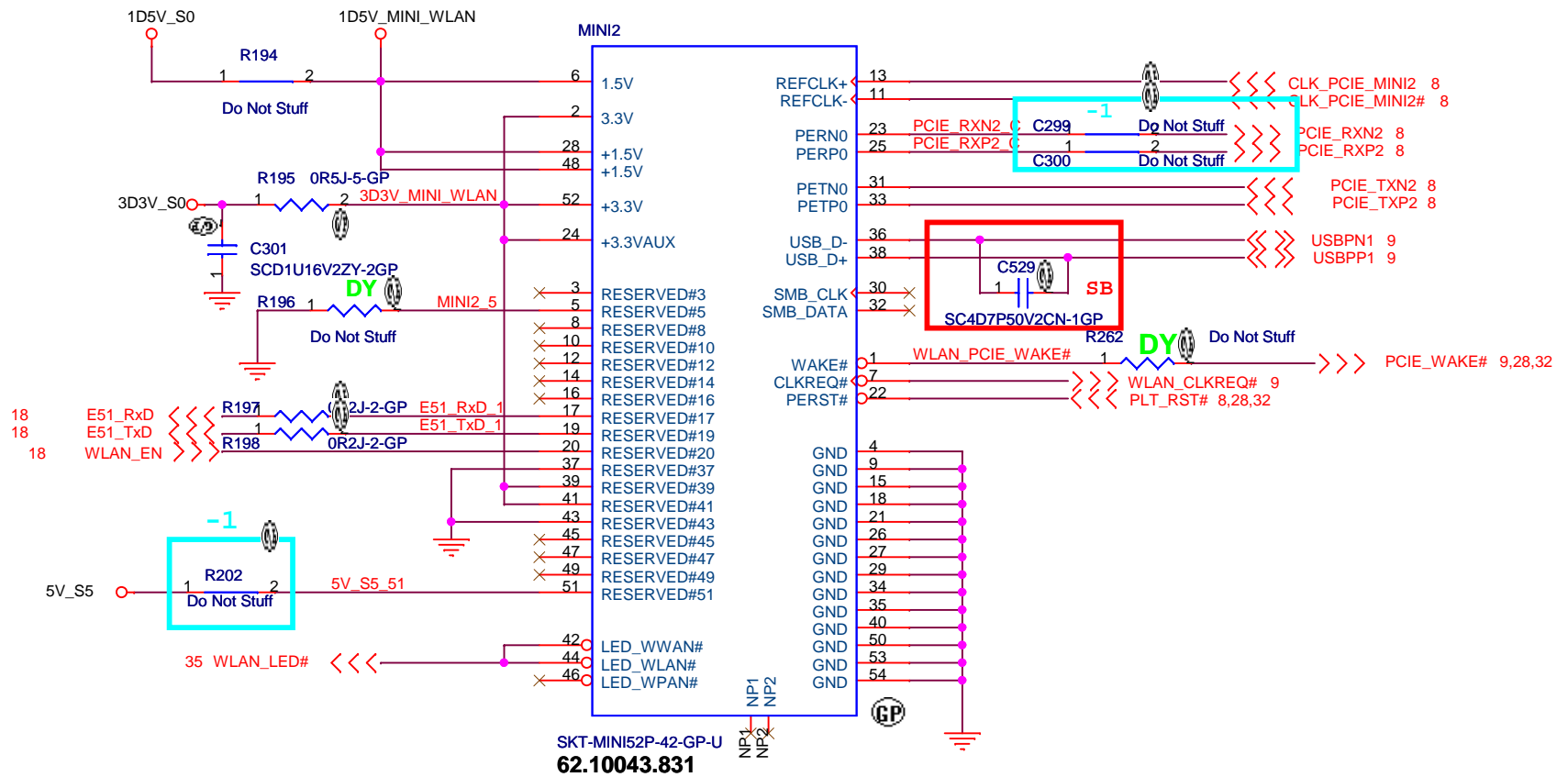

DUMMY

**緯創資通** **Wistron Corporation**  
 21F, 88, Sec.1, Hsin Tai Wu Rd., Hsichih,  
 Taipei Hsien 221, Taiwan, R.O.C.

Title **MINICARD WLAN**

Size	Document Number	Rev
	<b>LS205 MB</b>	<b>SB</b>

Date: Tuesday, December 21, 2010 Sheet 27 of 48



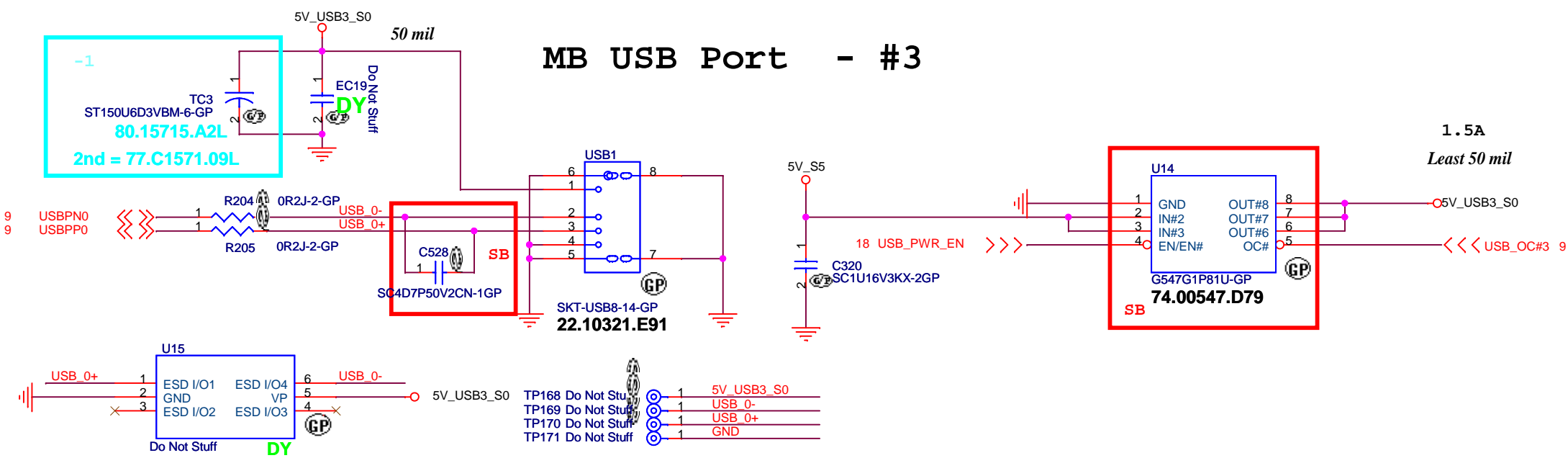

### IO BD USB Port - #1/#2

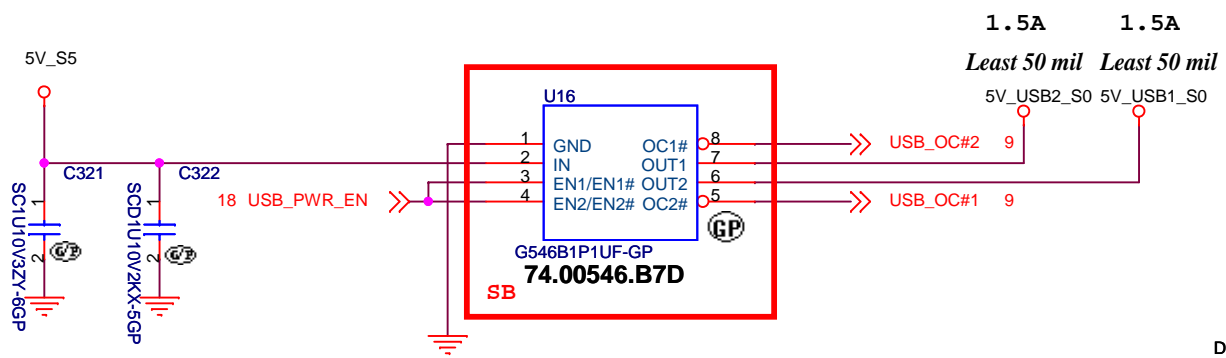

DUMMY		
<b>緯創資通</b>		<b>Wistron Corporation</b>
21F, 88, Sec.1, Hsin Tai Wu Rd., Hsichih, Taipei Hsien 221, Taiwan, R.O.C.		
<b>Title</b>		
<b>USB CONN</b>		
Size	Document Number	Rev
<b>LS205 MB</b>		<b>SB</b>
Date: Tuesday, December 21, 2010		Sheet 29 of 48

# Internal KeyBoard Connector

— << >> KCOL[15..0] 18  
— << >> KROW[7..0] 18

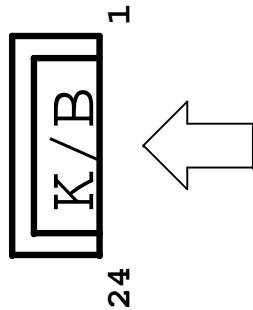

CONN PIN DEFINE 24 23 22 21 20 19 18 17 16 15 14 13 12 11 10 9 8 7 6 5 4 3 2 1  
 KB PIN DEFINE 1 2 3 4 5 6 7 8 9 10 11 12 13 14 15 16 17 18 19 20 21 22 23 24

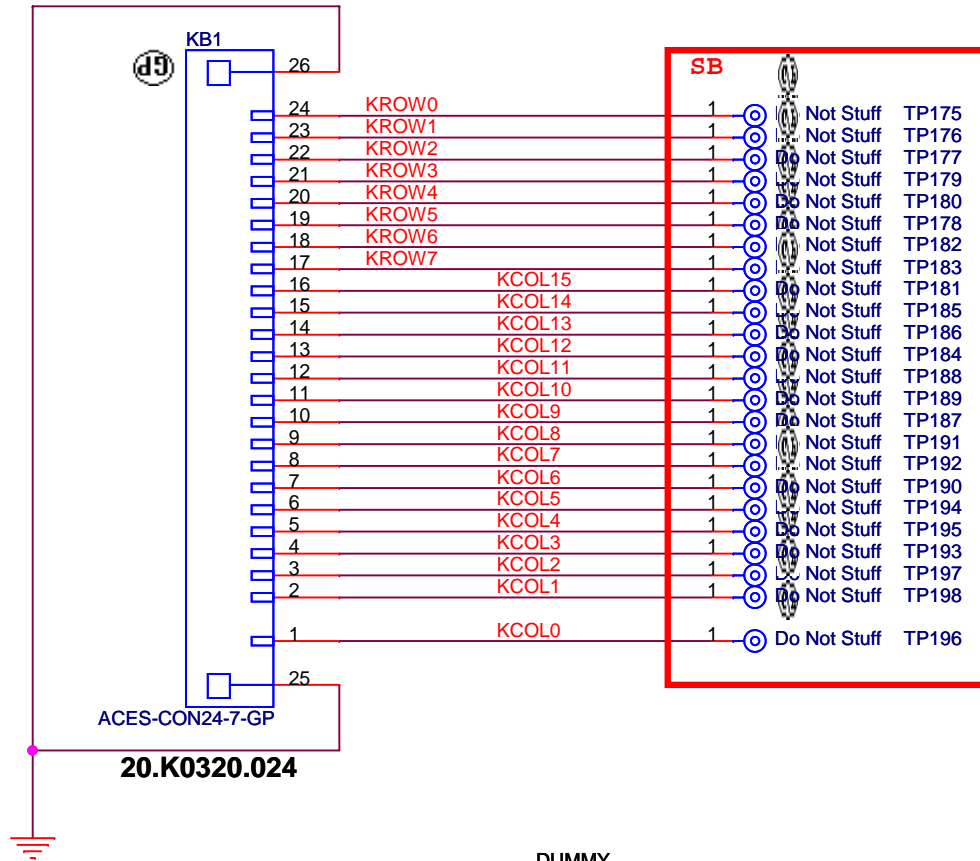

DUMMY

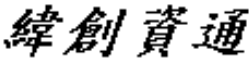
 <b>Wistron Corporation</b> 21F, 88, Sec.1, Hsin Tai Wu Rd., Hsichih, Taipei Hsien 221, Taiwan, R.O.C.	
<b>Title</b> <b>KB CONN</b>	
<b>Size</b> A	<b>Document Number</b> LS205 MB
<b>Rev</b> <b>SB</b>	
<b>Date:</b> Tuesday, December 21, 2010	
Sheet 30 of 48	

# TouchPad CONN

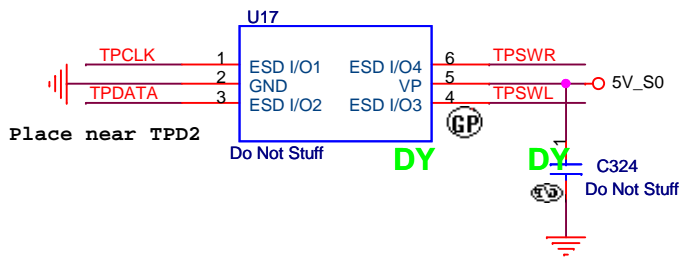
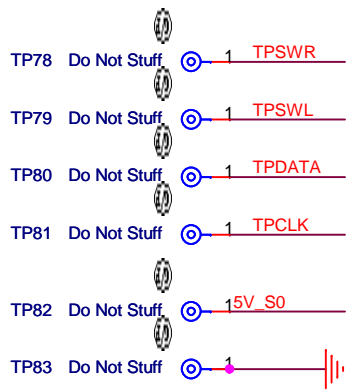
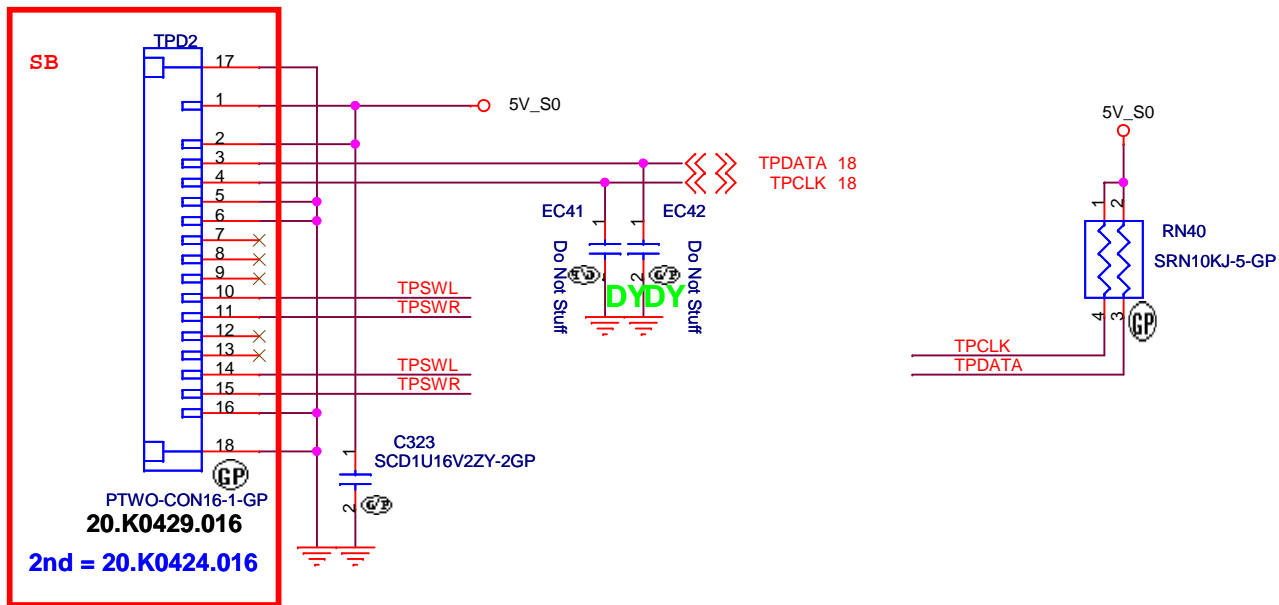

DUMMY

		<b>Wistron Corporation</b> 21F, 88, Sec.1, Hsin Tai Wu Rd., Hsichih, Taipei Hsien 221, Taiwan, R.O.C.	
<b>TouchPad CONN</b>			
Size	Document Number		Rev
	<b>LS205 MB</b>		<b>SB</b>
Date:	Tuesday, December 21, 2010	Sheet	31 of 48

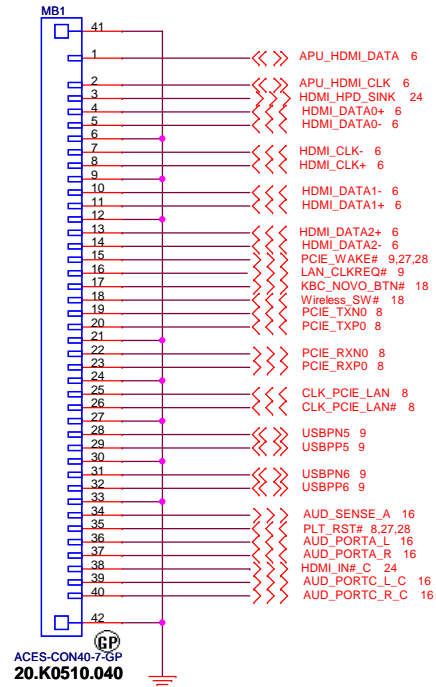
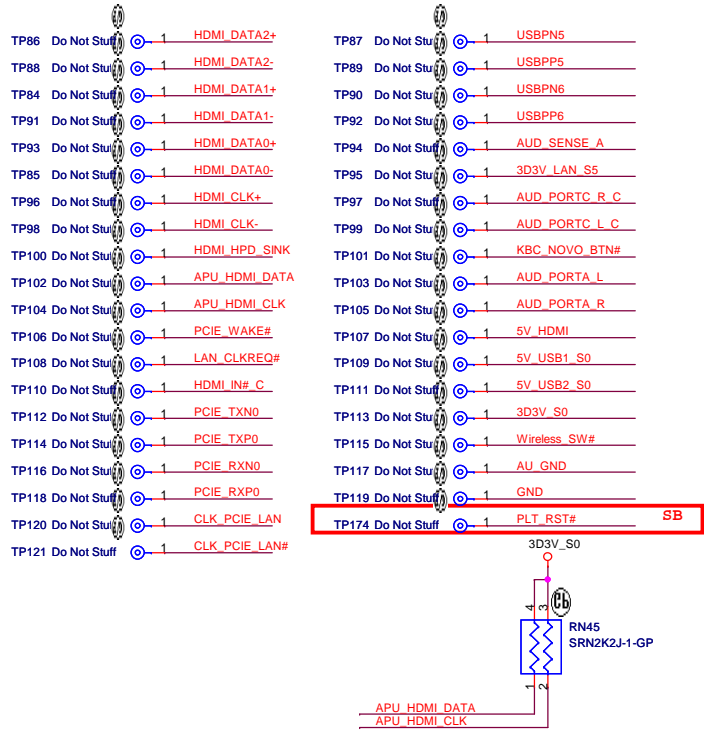

### To IO board

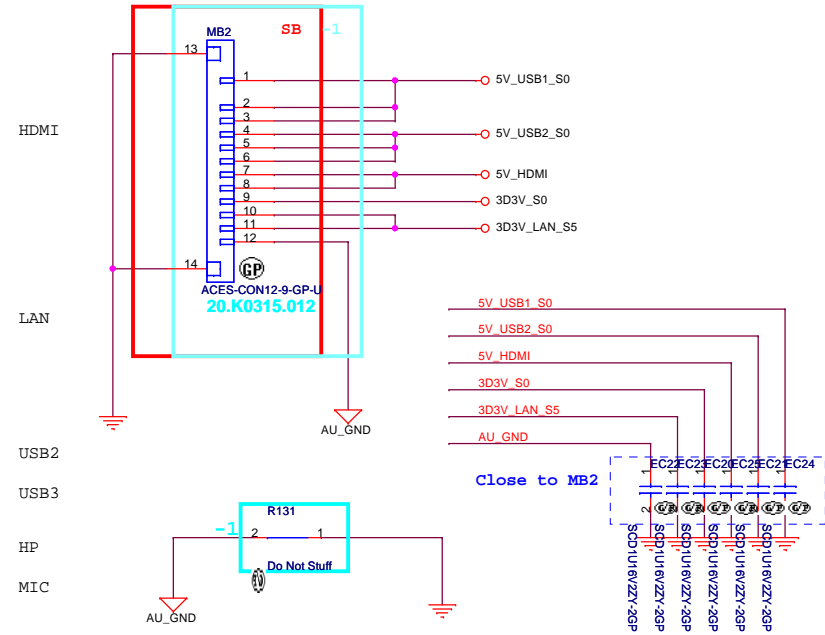

### HDMI POWER

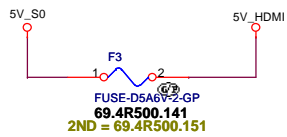

### LAN POWER

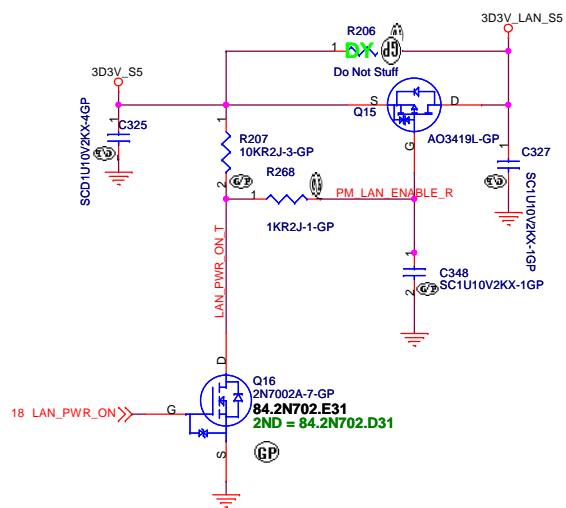

### A-Cover Lighting board

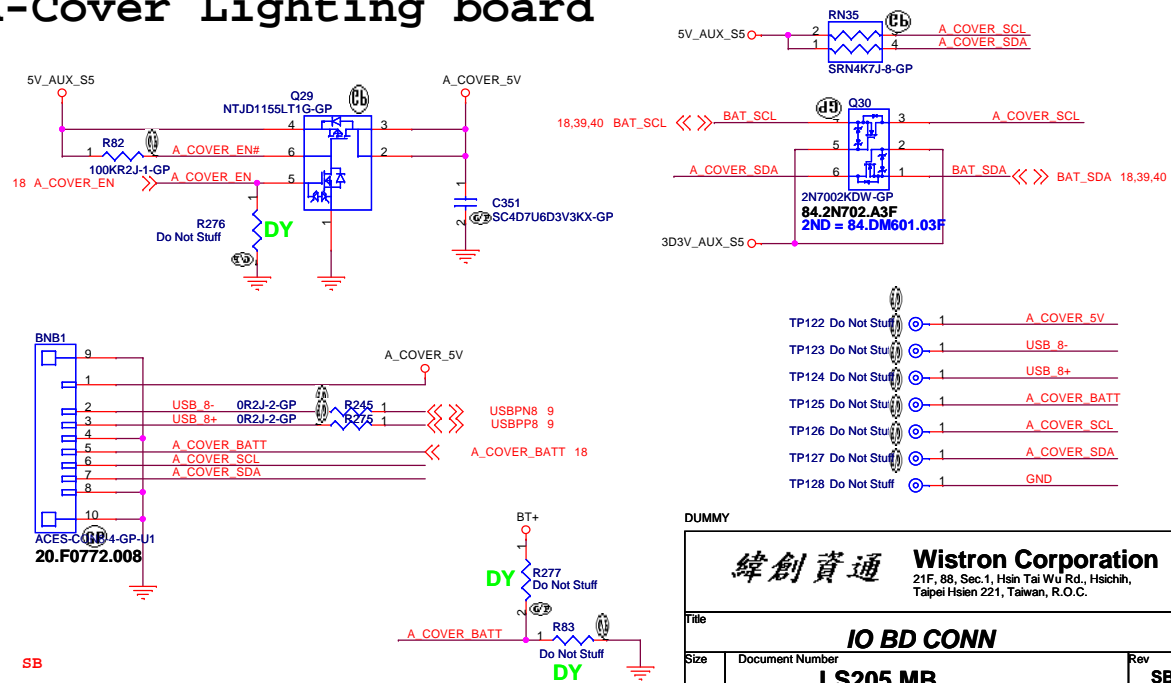

DUMMY

緯創資通 Wistron Corporation  
 21F, 88, Sec. 1, Hsin Tai Wu Rd., Hsichih, Taipei Hsien 221, Taiwan, R.O.C.

Title  
**IO BD CONN**

Size Document Number  
**LS205 MB**

Date: Tuesday, December 21, 2010 Sheet 32 of 48

Rev SB



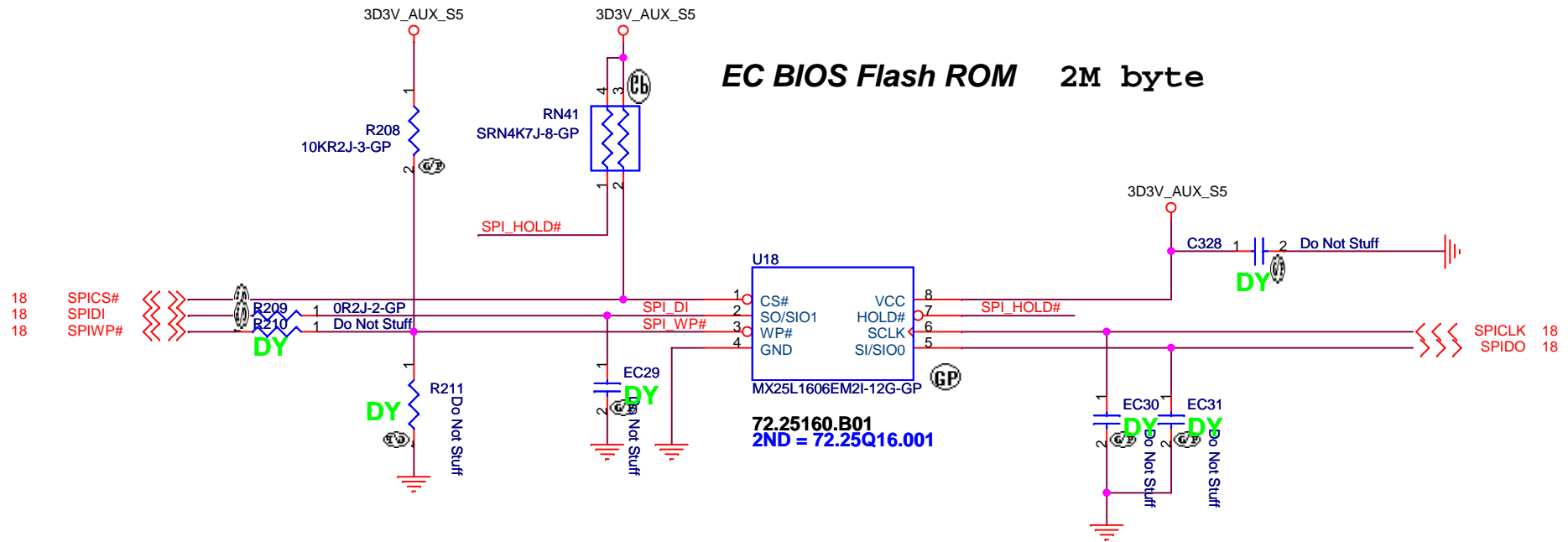

DUMMY

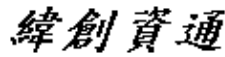
 <b>Wistron Corporation</b> 21F, 88, Sec.1, Hsin Tai Wu Rd., Hsichih, Taipei Hsien 221, Taiwan, R.O.C.	
<b>BIOS</b>	
Size	Document Number
<b>LS205 MB</b>	
Date: Tuesday, December 21, 2010	Rev SB
Sheet 33 of 48	

# Power Button

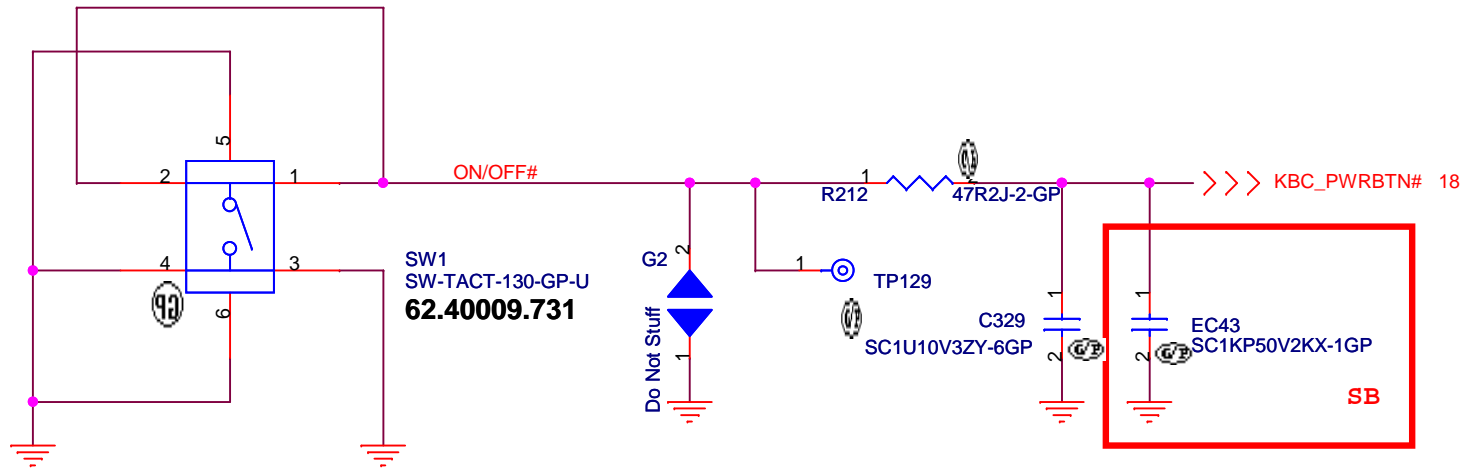

DUMMY

		<b>Wistron Corporation</b> 21F, 88, Sec.1, Hsin Tai Wu Rd., Hsichih, Taipei Hsien 221, Taiwan, R.O.C.	
Title <b>POWER BUTTON</b>			
Size A	Document Number <b>LS205 MB</b>		Rev <b>SB</b>
Date: Tuesday, December 21, 2010		Sheet 34 of	48

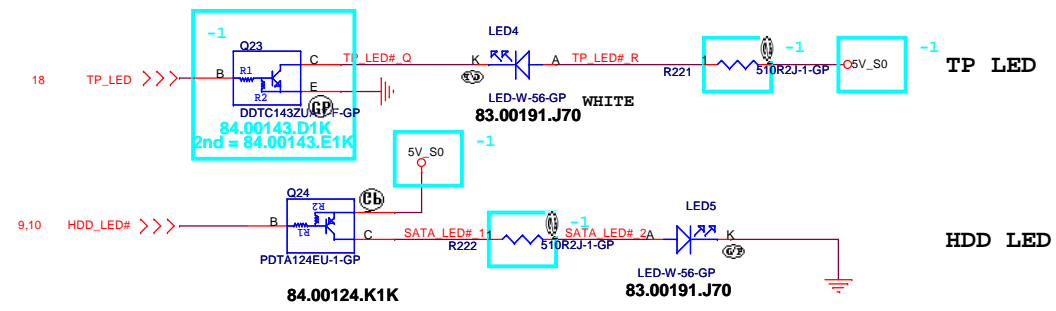
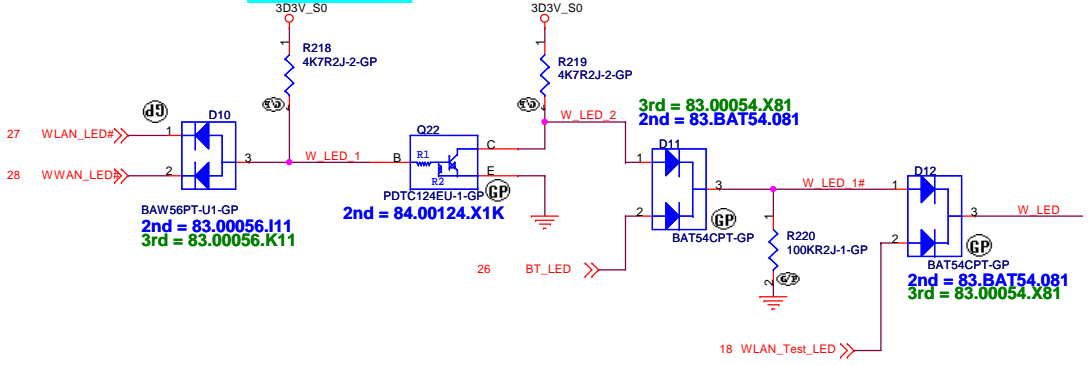
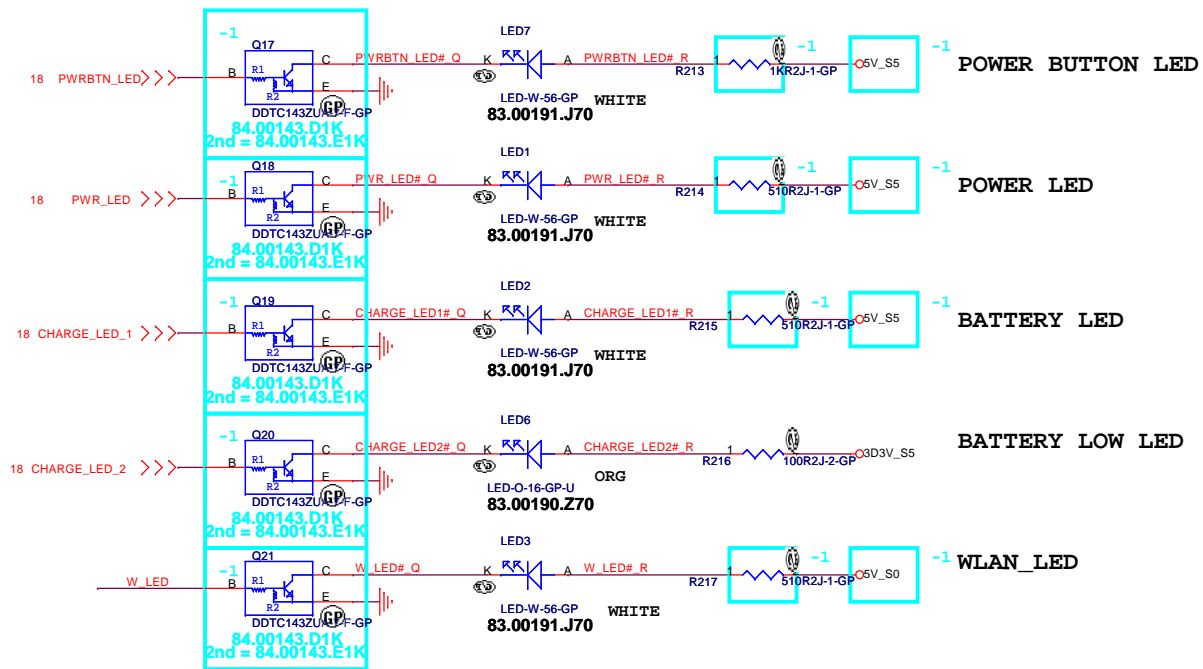

DUMMY

**緯創資通 Wistron Corporation**  
 21F, 88, Sec. 1, Hsin Tai Wu Rd., Hsichih, Taipei Hsien 221, Taiwan, R.O.C.

Title: **LED**

Size: Document Number: **LS205 MB** Rev: **SB**

Date: Tuesday, December 21, 2010 Sheet 35 of 48

# GOLDEN FINGER FOR DEBUG BOARD

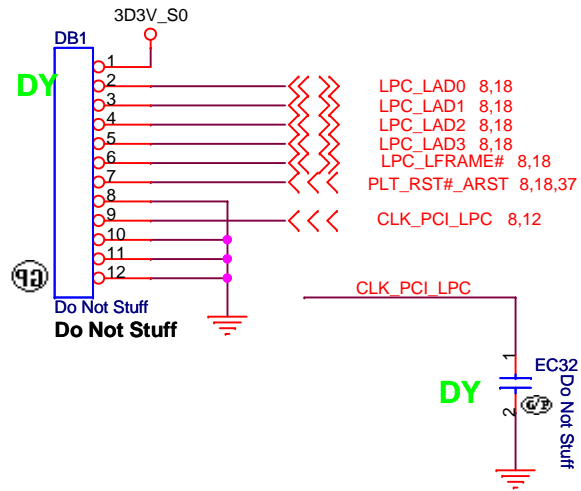

DUMMY

緯創資通

**Wistron Corporation**  
21F, 88, Sec.1, Hsin Tai Wu Rd., Hsichih,  
Taipei Hsien 221, Taiwan, R.O.C.

Title

**Debug Port**

Size

Document Number

**LS205 MB**

Rev

**SB**

Date: Tuesday, December 21, 2010

Sheet 36 of 48

# Run Power

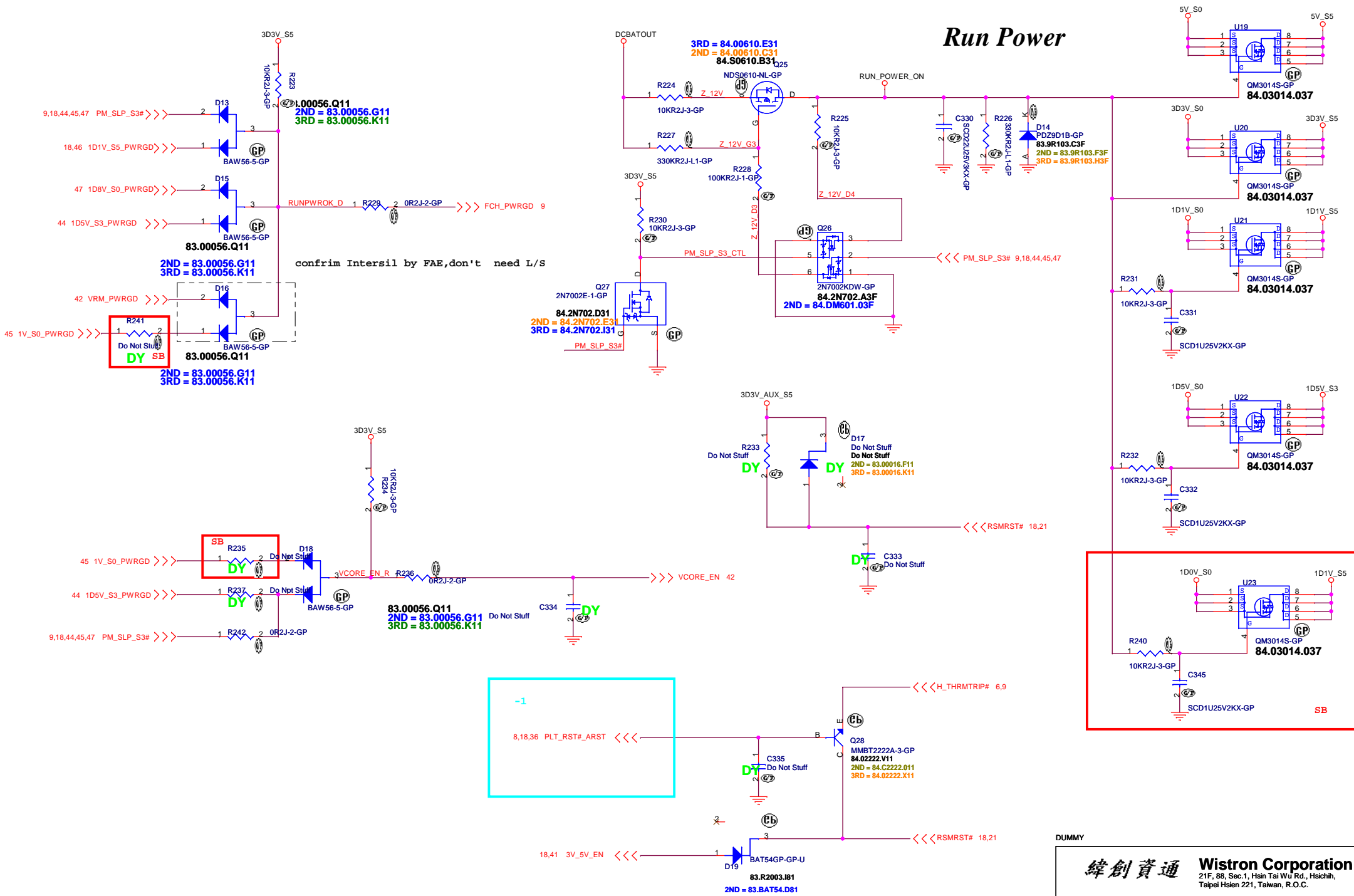

**DUMMY**

**緯創資通 Wistron Corporation**  
 21F, 88, Sec.1, Hsin Tai Wu Rd., Hsichih, Taipei Hsien 221, Taiwan, R.O.C.

**File** RUN POWER

**Size** Document Number **LS205 MB** **Rev** SB

Date: Tuesday, December 21, 2010 Sheet 37 of 48

**CPU\_CORE**  
ISL6265C

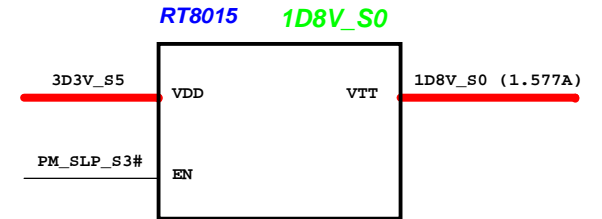
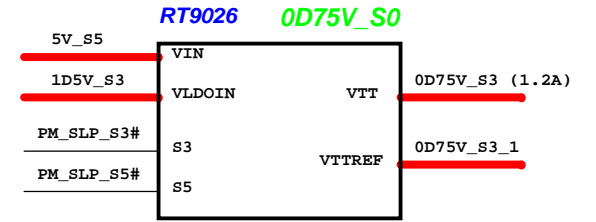
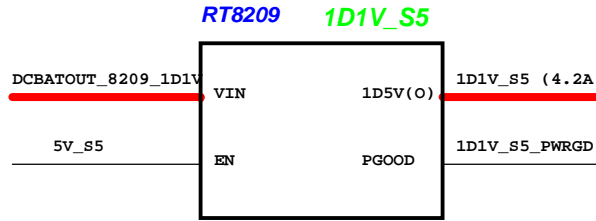
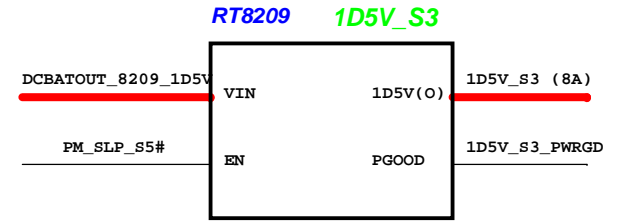
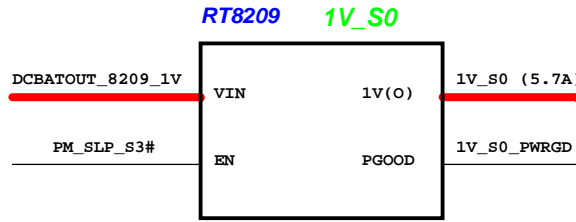
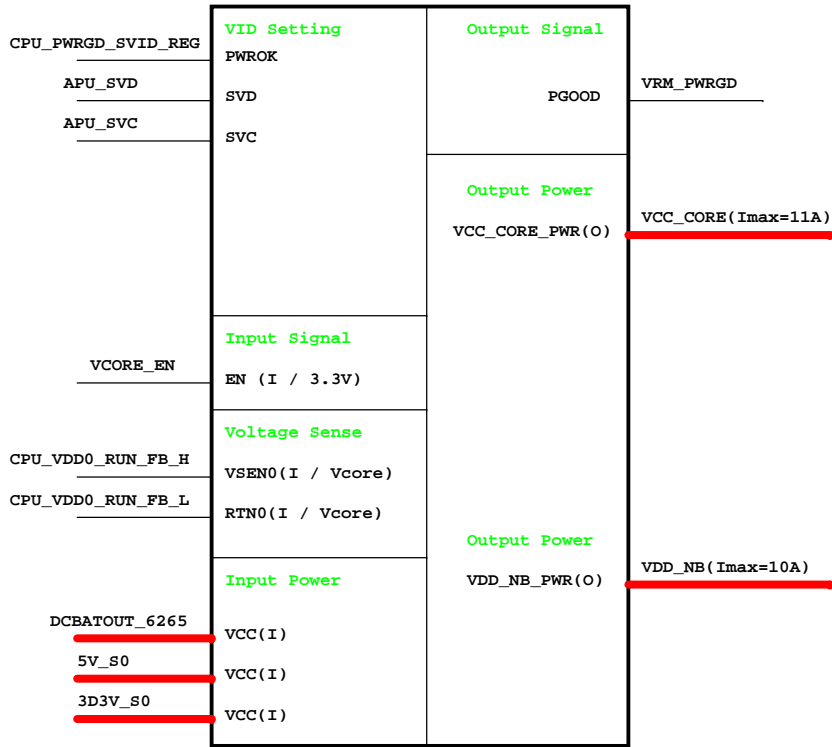

**5V/3D3V**  
RT8223

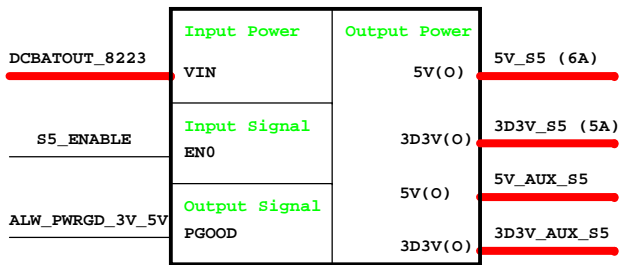

**Charger BQ24751**

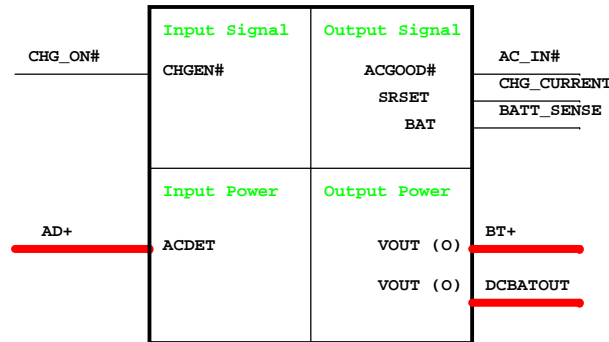

**Adapter**

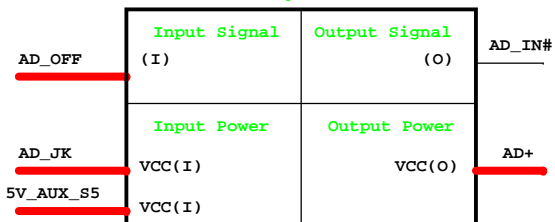

DUMMY

<b>緯創資通</b>		<b>Wistron Corporation</b>	
<small>21F, 88, Sec. 1, Hsin Tai Wu Rd., Hsichih, Taipei Hsien 221, Taiwan, R.O.C.</small>			
<b>Power Sequence Logic</b>			
Title	Document Number		Rev
Size	LS205 MB		SB
A3	Date: Tuesday, December 21, 2010		Sheet 38 of 48

# Adaptor in to generate DCBATOUT

TP161 Do Not Stuff  
 TP162 Do Not Stuff  
 TP163 Do Not Stuff

Do Not Stuff TP160  
 Do Not Stuff TP130  
 Do Not Stuff TP131

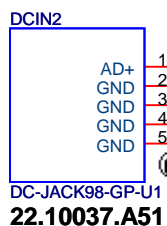

DC-JACK98-GP-U1  
**22.10037.A51**

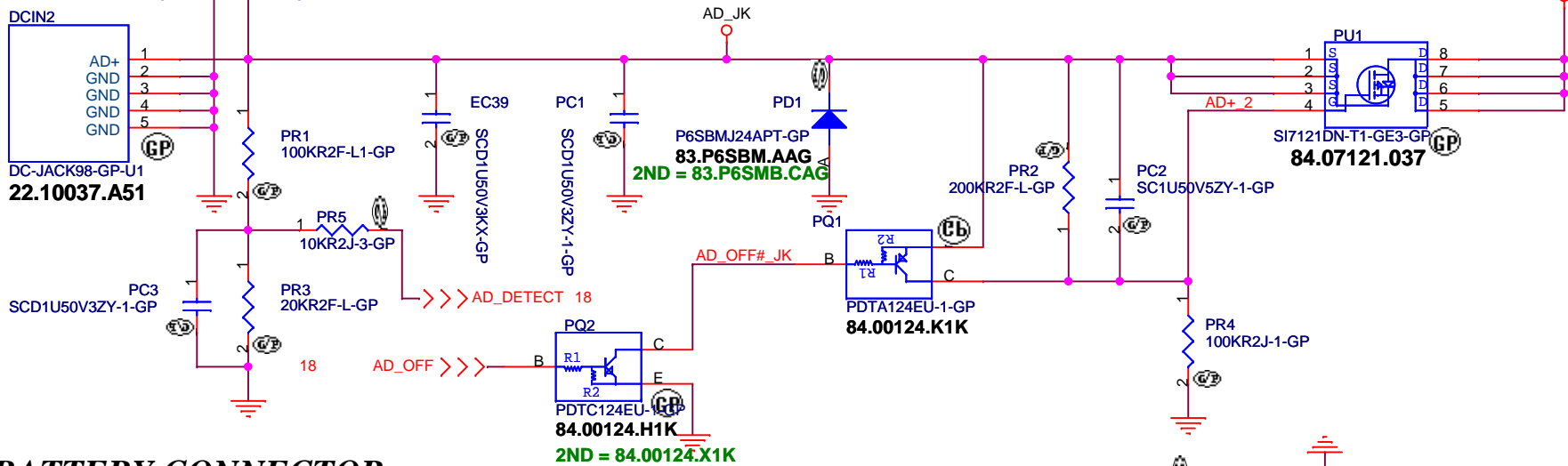

# BATTERY CONNECTOR

18,32,40 BAT\_SDA  
 18,32,40 BAT\_SCL  
 18 BAT\_IN#

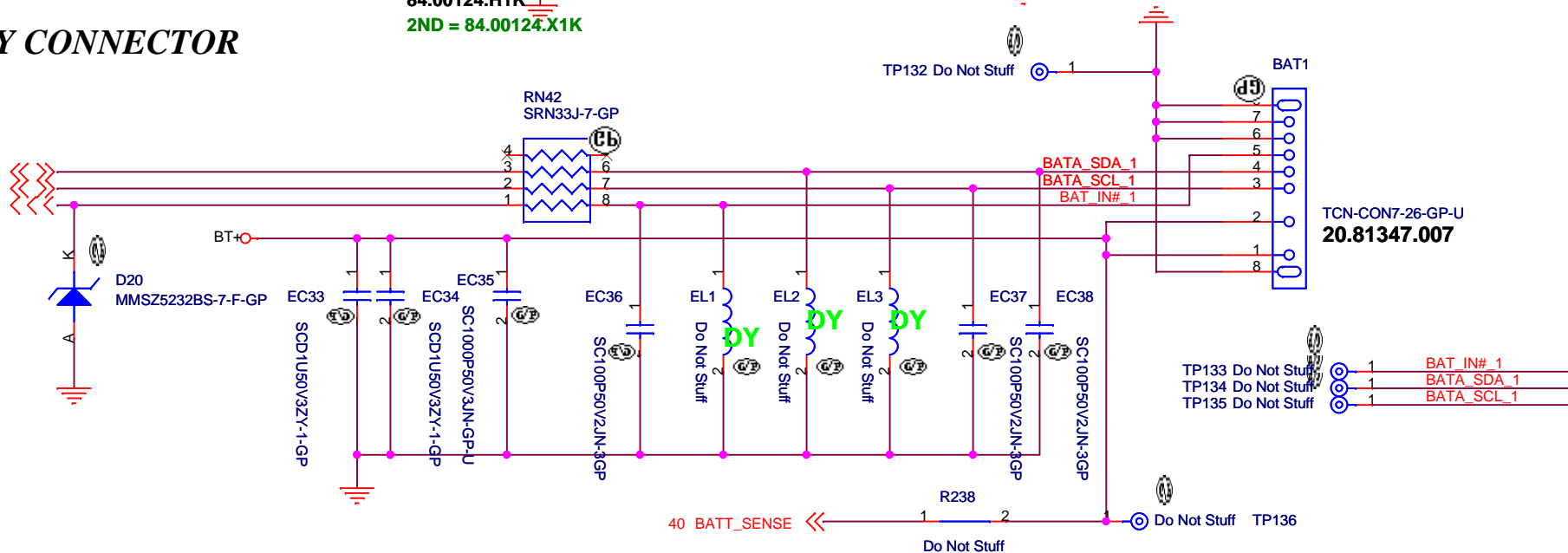

DUMMY

**緯創資通** **Wistron Corporation**  
 21F, 88, Sec.1, Hsin Tai Wu Rd., Hsichih,  
 Taipei Hsien 221, Taiwan, R.O.C.

Title <b>AD / BATT CONN</b>		
Size A4	Document Number <b>LS205 MB</b>	Rev <b>SB</b>
Date: Tuesday, December 21, 2010		
Sheet 39		of 48

AD+ total power	R1	R2
65w	187k	49.9k
<b>40w</b>	348k	49.9k

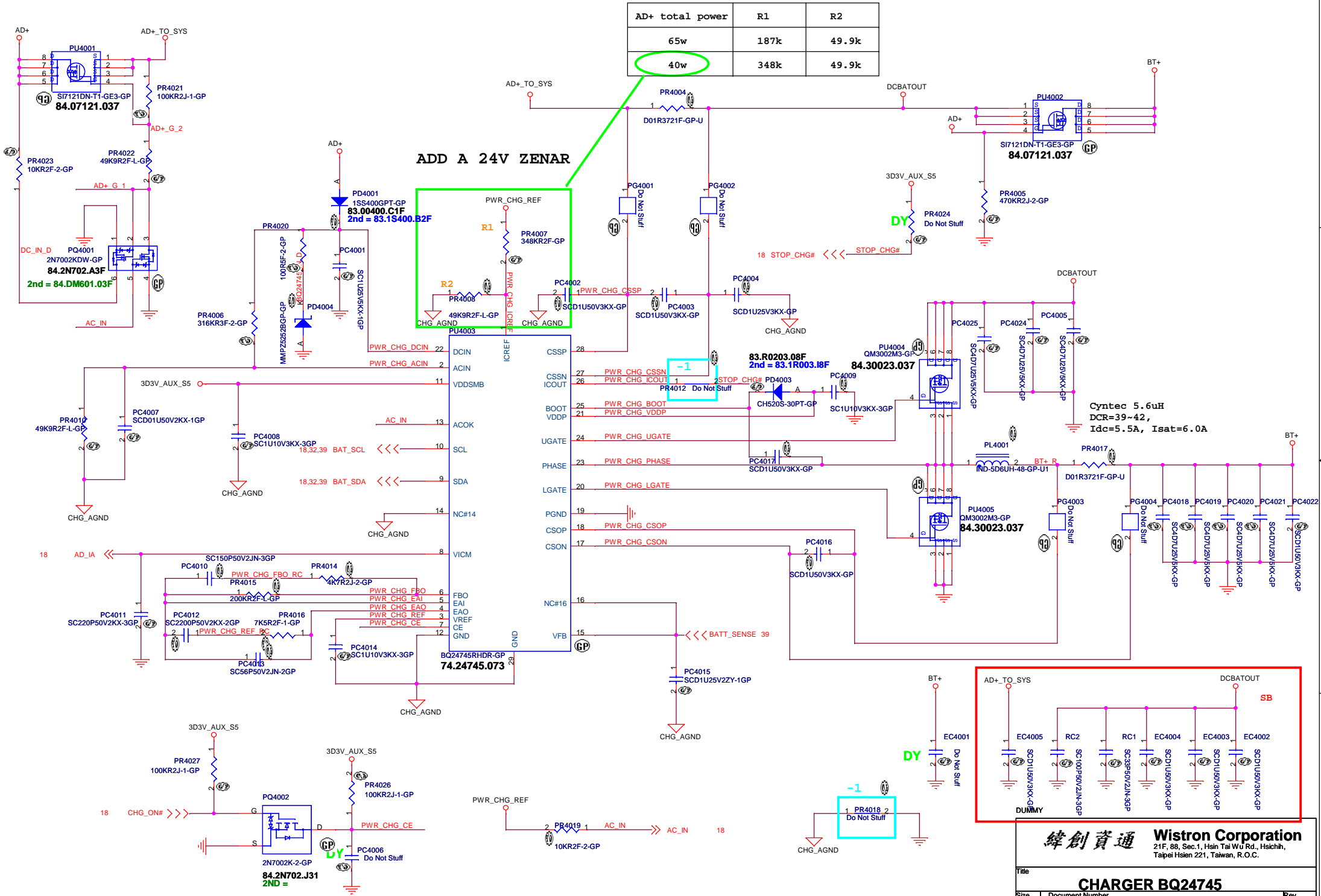

ADD A 24V ZENAR

Cyntec 5.6uH  
DCR=39-42,  
Idc=5.5A, Isat=6.0A

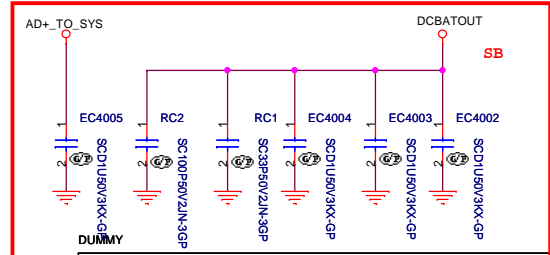

緯創資通 Wistron Corporation  
21F, 88, Sec.1, Hsin Tai Wu Rd., Hsichih,  
Taipei Hsien 221, Taiwan, R.O.C.

Title	<b>CHARGER BQ24745</b>	
Size	Document Number	Rev
A3	<b>LS205 MB</b>	SB
Date: Tuesday, December 21, 2010	Sheet 40	of 48



SSID = PWR.Plane.Regulator\_5v3p3v

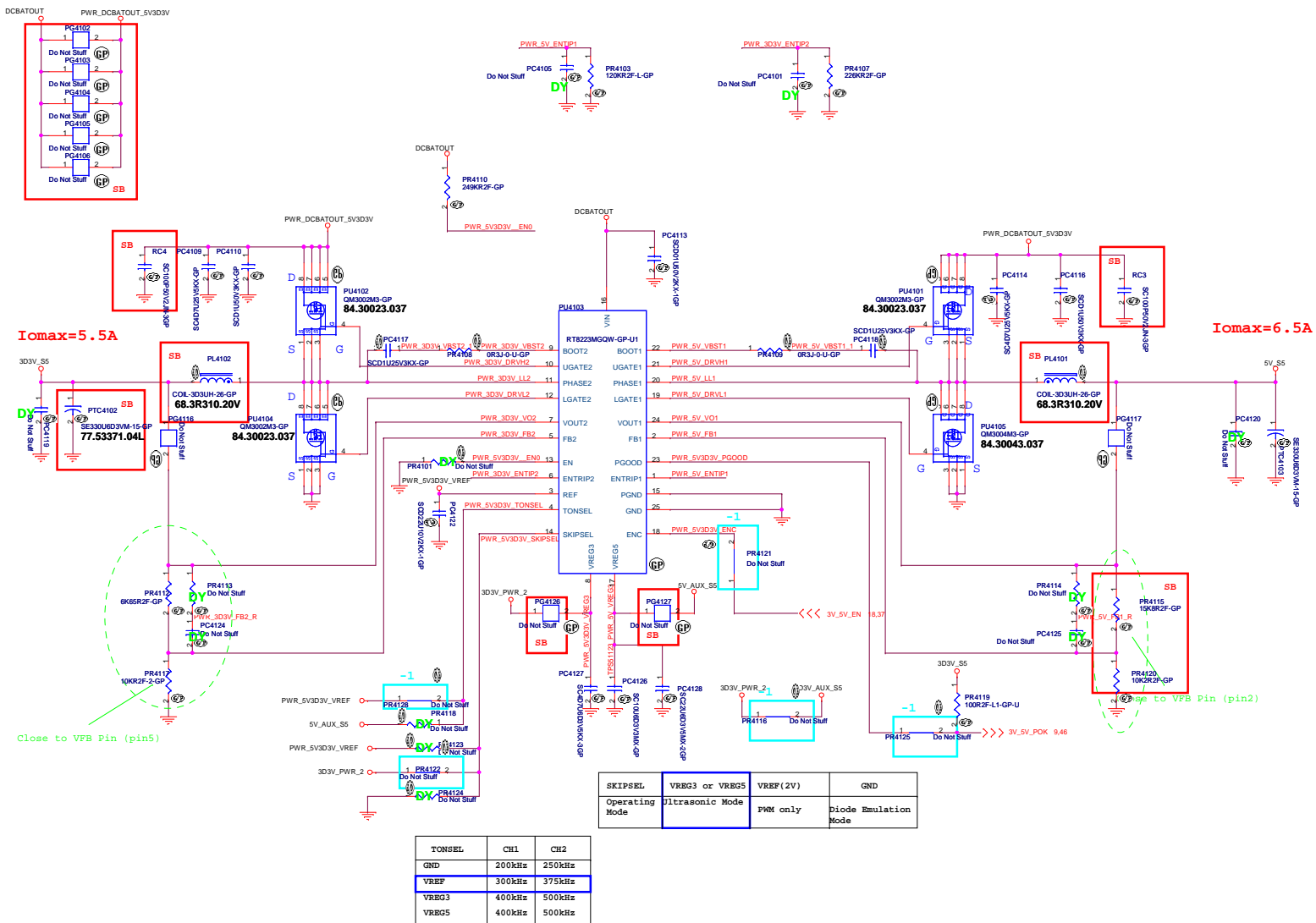

DUMMY

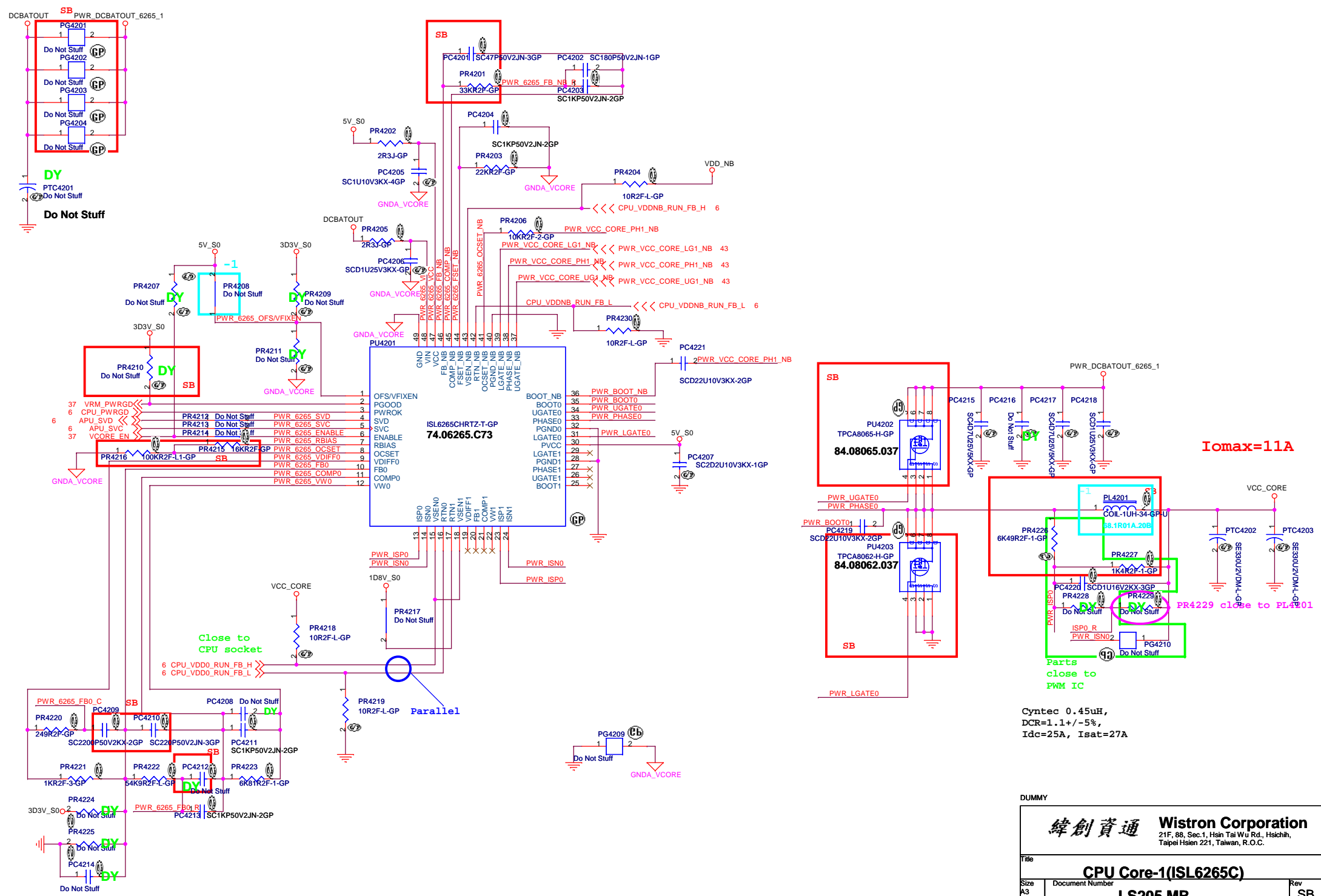

**I<sub>omax</sub>=11A**

Cyntec 0.45uH,  
DCR=1.1+/-5%,  
I<sub>dc</sub>=25A, I<sub>sat</sub>=27A

DUMMY

緯創資通		<b>Wistron Corporation</b>	
		21F, 8B, Sec.1, Hsin Tai Wu Rd., Hsichih, Taipei Hsien 221, Taiwan, R.O.C.	
<b>Title</b>			
<b>CPU Core-1(ISL6265C)</b>			
Size	Document Number	Rev	
A3	<b>LS205 MB</b>	SB	
Date:	Tuesday, December 21, 2010	Sheet	42 of 48

DCBATOUT PWR\_DCBATOUT\_VDDNB

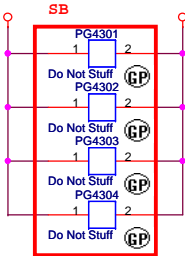

PWR\_DCBATOUT\_VDDNB

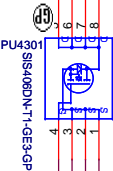

Id=7.3A,  
Rdson=11.5~14.5,  
Qg=8.4~13nC

- 42 PWR\_VCC\_CORE\_UG1\_NB >>
- 42 PWR\_VCC\_CORE\_PH1\_NB >>
- 42 PWR\_VCC\_CORE\_LG1\_NB >>

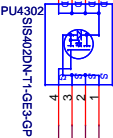

Id=15A,  
Qg=12~21nC,  
Rdson=6.4~8mohm

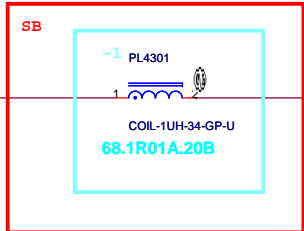
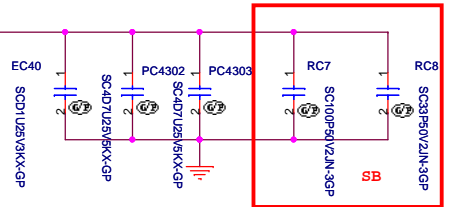

Iomax=10A

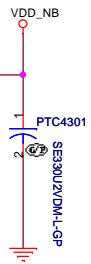

VDD\_NB

DUMMY

		<b>Wistron Corporation</b> 21F, 8B, Sec.1, Hsin Tai Wu Rd., Hsichih, Taipei Hsien 221, Taiwan, R.O.C.	
<b>CPU Core-2(ISL6265C)</b>			
Size A3	Document Number <b>LS205 MB</b>	Rev <b>SB</b>	
Date: Tuesday, December 21, 2010		Sheet 43 of 48	

DCBATOUT PWR\_DCBATOUT\_1D5V

# TPS51218 for 1D5V

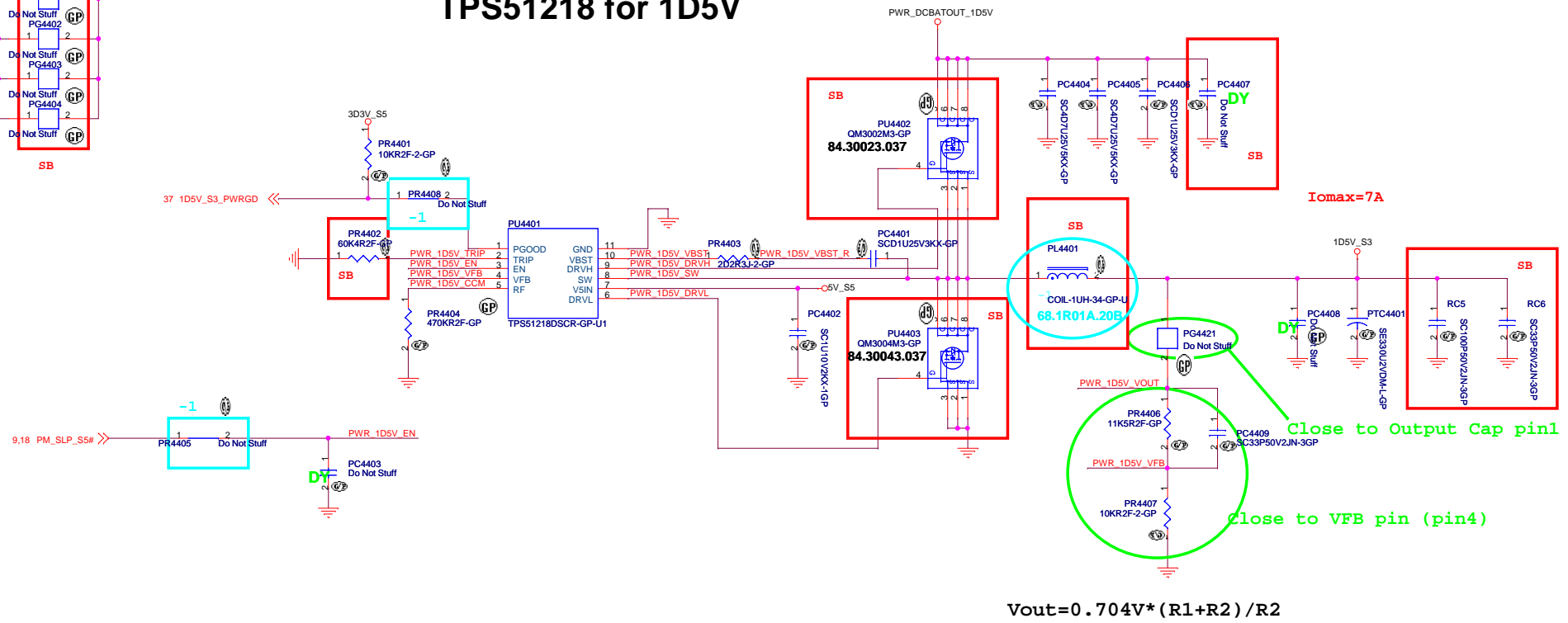

# G2997B for 0D75V\_S3

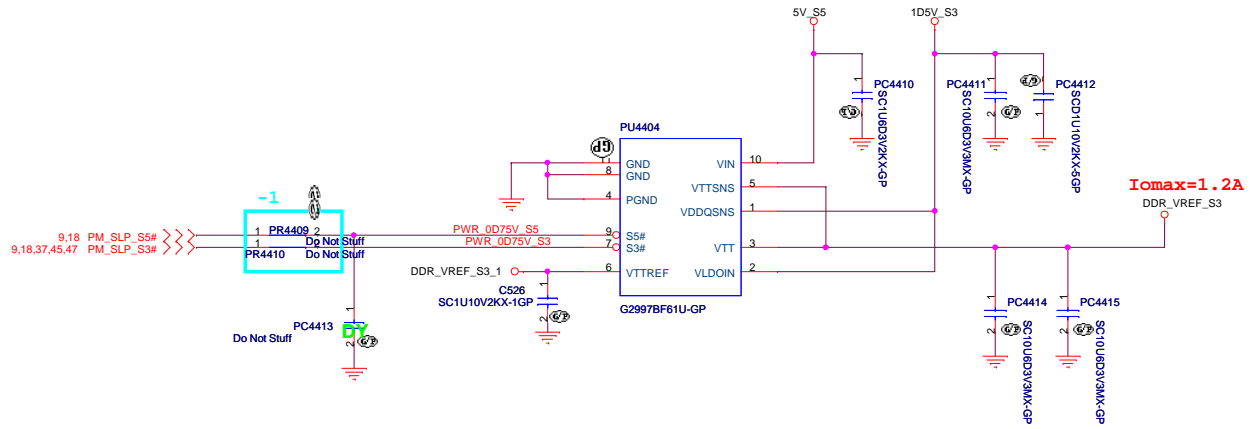

DUMMY

**緯創資通 Wistron Corporation**  
 21F, 88, Sec.1, Hsin Tai Wu Rd., Hsichih, Taipei Hsien 221, Taiwan, R.O.C.

Title: **DC to DC 1D5V(TPS51218)**

Size: Document Number  
 Custom: **LS205 MB** Rev: SB

Date: Tuesday, December 21, 2010 Sheet 44 of 48

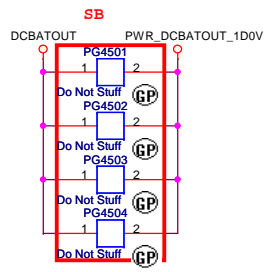

# RT8209P for 1D0V

PWR\_DCBATOUT\_1D0V

PU4502 Do Not Stuff

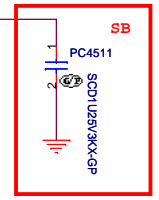

I<sub>omax</sub>=5.7A

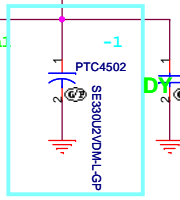

PU4503 Do Not Stuff

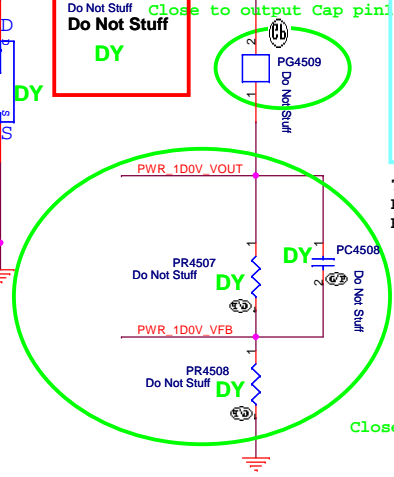

5V\_S5

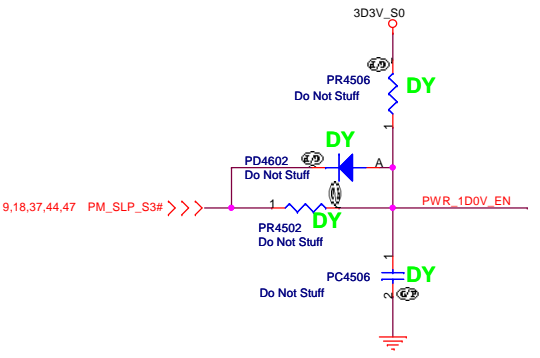
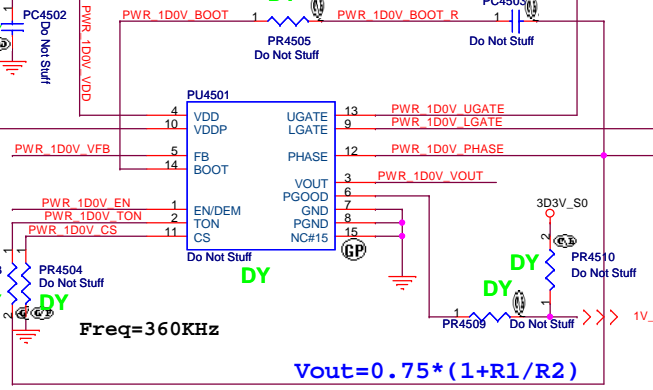
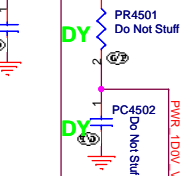

DUMMY

<b>Wistron Corporation</b> 21F, 88, Sec.1, Hsin Tai Wu Rd., Hsichih, Taipei Hsien 221, Taiwan, R.O.C.	
<b>DC to DC 1D0V(RT8209P)</b>	
Size A3	Document Number
<b>LS205 MB</b>	
Date: Tuesday, December 21, 2010	Sheet 45 of 48
Rev SB	

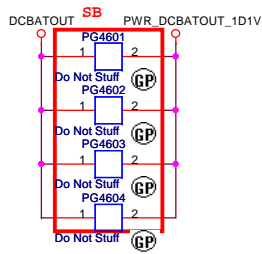

# RT8209P for 1D1V

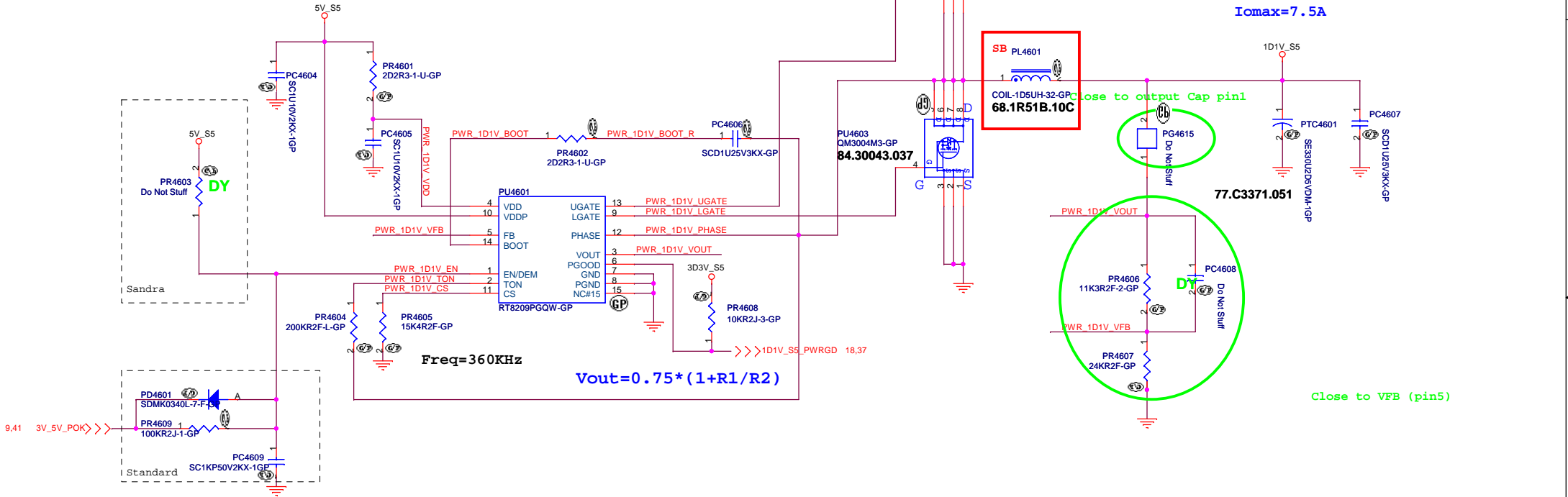

DUMMY			
緯創資通		Wistron Corporation	
21F, 88, Sec.1, Hsin Tai Wu Rd., Hsichih, Taipei Hsien 221, Taiwan, R.O.C.			
Title			
DC to DC 1D1V(RT8209P)			
Size	Document Number	Rev	
A3	LS205 MB	SB	
Date:	Tuesday, December 21, 2010	Sheet	46 of 48

**SSID = PWR.Plane.Regulator\_1p8v**

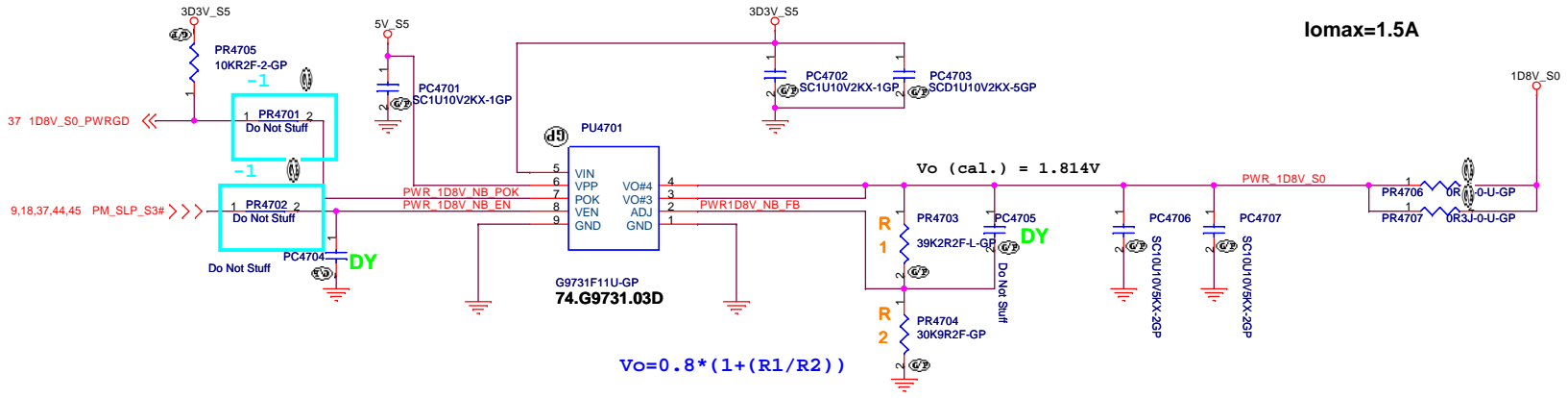

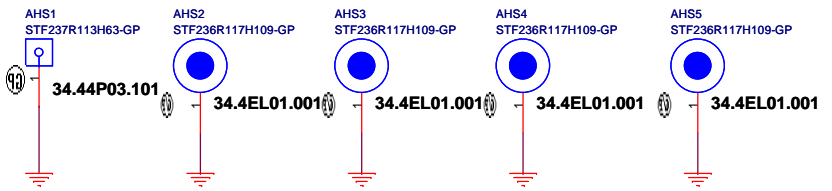
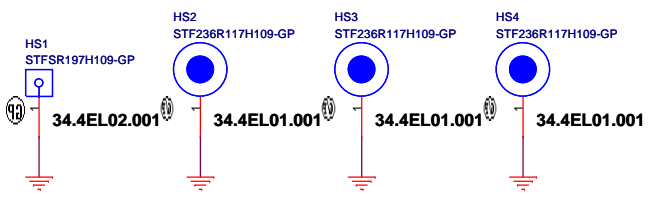
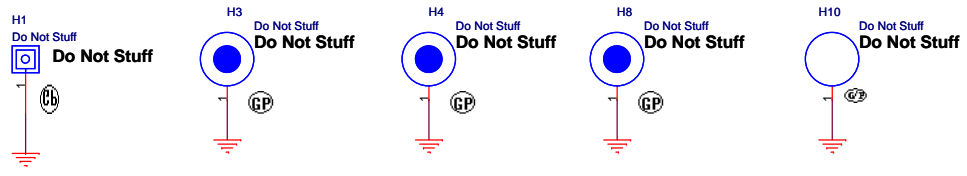

DUMMY

<b>Wistron Corporation</b> 21F, 88, Sec. 1, Hsin Tai Wu Rd., Hsichih, Taipei Hsien 221, Taiwan, R.O.C.		
<b>SPRING/HALL</b>		
Size A3	Document Number <b>LS205 MB</b>	Rev <b>SB</b>
Date: Tuesday, December 21, 2010		
Sheet 48		of 48